

Axlebox designs

Extract from the Railway technical handbook,
volume 1, chapter 3, page 42 to 71



3 Axlebox designs

Capabilities	43
Specifications	45
Validation	49
Designs	54
Calculation	62
Industrialization	69
Testing	70



Axlebox designs

Axleboxes are the linking design element between the rotating wheelset and the quasi-static frame of the bogie or running gear of a railway vehicle. All forces acting between these components are transmitted via springs, dampers and guiding elements. Axleboxes and axlebox bearings/units have always been a vital component in the reliability of railway rolling stock and they have a considerable influence on the operating safety, reliability and economics of railways.

Capabilities

SKF has a unique experience in developing, designing, calculating and performing validation testing on axleboxes for all kinds of railway vehicles such as high-speed vehicles, locomotives, multiple units, coaches, mass transit vehicles and freight cars. Most high-speed trains are equipped with SKF solutions.

Millions of SKF axleboxes are in service throughout the world in every climate, from moderate Mediterranean to tropical desert to sub-zero wilderness.

Customized solution packages for railway vehicle manufacturers and operators are based on individual specifications.

These packages are typically composed of axleboxes, factory lubricated and sealed, ready-to-mount axlebox bearing units, sensors and monitoring systems as well as subsystems like high performance AMPEP self-lubricating spherical plain bearings, articulation joints, wheel flange lubrication

systems etc. (→ **chapter 9**). SKF offers a unique experience in handling these projects including engineering, logistics and after-sales service options.

Axlebox designs contain axlebox bearing units and AXLETRONIC sensors (→ **chapter 7**) and have to be linked with the wheelset journal geometry as well as further bogie design subsystems like guiding elements, springs, dampers, earth return devices, etc.

Subsystems and components interacting with the axlebox design

Bogie	Wheelset	Axlebox assembly Axlebox	Bearing	AXLETRONIC sensor
Guiding elements	Axle journals	Axlebox housing assembly	Tapered and cylindrical roller bearing units	Detection: <ul style="list-style-type: none"> • Rotation • Direction of rotation • Speed • Vibration • Operating temperature
Dampers	End caps	Mounting and dismounting capabilities	Open bearing sets like cylindrical and spherical roller bearings	
Primary springs	Backing rings		AMPEP plain bearings	
Silent blocks	Labyrinth rings			
Rods	Inspection capability like ultrasonic non-destructive crack detection			
Earth returns				
Life guards				
Lifting devices				
Stoppers				
Slippers				
Rail brakes				
3rd rail current collector attachments				

Main competence requirements for axlebox design

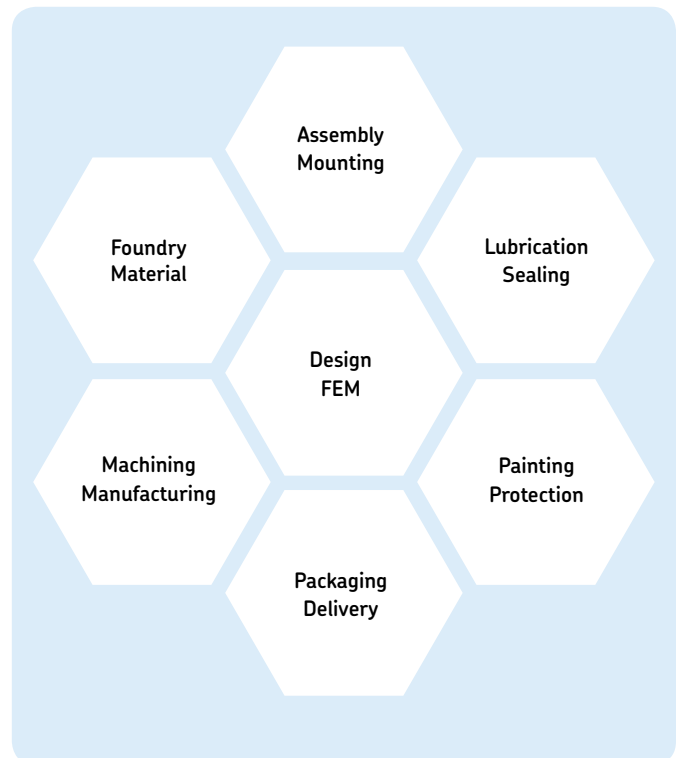

SKF axlebox benefits

- comprehensive system solution supply integrated into the train bogie subsystem
- one-stop shopping
- competent handling of the interface between bearing and housing
- customized engineering and logistic solutions
- ready-to-mount packages
- high engineering competencies
- global customer support and project handling
- after-sales service options

Specifications

High quality specifications are a key factor in providing a functional design that can achieve high reliability and safety as well as low life cycle cost. In most business cases, the bogie manufacturer submits specifications for the axlebox engineering and logistics. However, these specifications could refer to additional specifications to be considered that are based on operators, wheelset suppliers, standardization bodies, consultants requirements and domestic/international standards. The main objective is to gather and summarize all individual standards, requirements and expectations.

Specifications have to consider the interaction of several bogie subsystems with the axlebox system in the context of a specific vehicle application. Therefore, the overall axlebox performance can relate only to the complete vehicle and not to the individual elements of bogies or running gear.

There are several European standards, either published or available as drafts, which are very helpful in communicating with operators as well as vehicle, bogie and bogie subsystems and component suppliers with SKF as the axlebox supplier.

General bogie and axlebox requirements

The supply of bogies/running gear as well as of axleboxes shall be based on a comprehensive specification that is agreeable to both the customer and the supplier. The specification shall include information defining the intended operating conditions of the bogie or running gear:

- vehicle space envelope
- physical connections
- payload and load inputs
- traction system and performance
- brake system and performance
- hot axlebox detection (HABD)
- other auxiliary systems (e.g. track/train communications)
- vehicle gauge
- track characteristics
- operating environment
- duty cycles
- noise and vibration regulations

Source: prEN 15827-1:2008 Bogies and running gear

Terms and definitions

- **Bogie frame:** load-bearing structure generally located between the primary and secondary suspension
- **Bolster:** transverse load-bearing structure generally located between vehicle body and bogie frame
- **Sideframe:** longitudinal structural member of the bogie frame
- **Headstock:** transverse member joining the longitudinal extremities of the bogie sideframes
- **Transom:** central transverse structural member(s) of the bogie frame
- **Axlebox:** assembly comprising the axlebox housing, rolling bearings, sealing solution and grease
- **Box housing:** load-bearing structure housing the bearings, grease, sealing and accessories
- **Primary suspension:** suspension system consisting of the resilient elements, generally located between the axlebox and bogie frame
- **Secondary suspension:** suspension system consisting of the resilient elements, generally located between the bogie frame and vehicle body or bolster
- **Static force:** force that is constant with time
- **Quasi-static force:** force that changes with time at a rate that does not cause dynamic excitation
- **Dynamic force:** transient, impulsive or continuous force, uniform or random, that changes with time at a rate that causes dynamic excitation
- **Load case:** a set of loads or combination of loads that represents a loading condition that acts on the structure or component
- **Exceptional load case:** load case used for assessment against static material properties
- **Fatigue load case:** repetitive load case used for assessment against durability
- **Safety factor:** a factor applied during the strength assessment, which makes an allowance for a combination of uncertainties and safety criticality
- **Validation:** the process of demonstrating by analysis and/or tests that the system under consideration meets in all respects the specification, including requirements due to regulations, for that system
- **Verification:** the process of demonstrating by comparison or testing that an analytical result or estimated value is of an acceptable level of accuracy

Source: prEN 13749:2008, Railway applications – Wheelset and bogies – Method of specifying the structural requirements of bogie frames

Structural integrity

For some components, such as a bogie frame or axlebox, transferring loads from one point to another is their primary function. But springs, dampers, etc. are also inherent load carrying parts. It follows that all parts shall be designed with a level of structural integrity compatible with the loads they carry.

Standard and regulations

Acceptance criteria shall comply with requirements of the normative references and current appropriate European standards. If these do not exist, acceptance shall be based on applicable national or international standards or alternative sources of equivalent standing. Where no appropriate data is available from standards, other data can be used, provided it is verified and supported by a documented quality control process.

New bogies and running gears are subject to existing and emerging legislation and regulations in the following areas:

- physical agents (vibration) directive
- EC noise directive
- toxic materials usage – RoHS (Restriction of Hazardous Substances Directive)
- pressure vessels
- waste disposal
- product disposal at life expiry

Vehicle conditions and interfaces

Specifications should include, but not be limited to, the following information:

- vehicle masses
- vehicle geometry (e.g. available space, position of the centre of gravity)
- body–bogie connections (e.g. mechanical, pneumatic, electric)
- braking equipment
- motors and transmission
- active suspension systems (including tilt where applicable)
- loading conditions (e.g. changes in payload and frequency, dynamic load spectra)
- method of loading (e.g. progressive or sudden)
- maintenance loading due to lifting, jacking, etc.
- maximum axleloads
- maximum operating speed
- speeds on curves and cant deficiency
- starts and stops (i.e. number and frequency, acceleration rates, deceleration rates, including non-scheduled stops)
- wheel slip/slide control system characteristics
- exceptional conditions (e.g. derailments, lifting, recovery, allowable instability)
- layout of the tracks, including service depot tracks, (e.g. minimum radius of curves, number and radius of curves)
- indication of distance covered on straight lines and on curves, maximum and normal levels of twist, percentage of use on service depot tracks, number of junctions, cant
- types of track (e.g. classification of quality including construction, roughness and discrete irregularities)
- loading gauge and method of conformance demonstration
- climatic conditions (e.g. temperature, humidity, rain, snow, floods, wind)
- aggressive agents (e.g. corrosion, erosion, dirt)
- description of maintenance operations, including their frequency
- the use of machines for washing (cleaning agents)
- handling requirements (e.g. lifting, towing, recovery)
- depot facilities

The customer should indicate in the technical specification any particular requirements that are not covered by the above descriptions, for example, materials, components, types of construction and methods of assembly, operating and maintenance staff skills.

Source: prEN 15827-1:2008, Bogies and running gear

Bogie classification

For reference purposes, it is convenient to assign bogies to different categories. Although identified generally in terms of vehicle types, the selection of the category for a bogie should also take into account the structural requirements of the bogie frame. The structural requirements for bogies in a particular category are not unique and shall always be defined according to the operating requirements. Some bogies may not fit into any of the defined categories as mentioned in prEN 15827-1:2008:

- category B-I bogies: for main line and inter-city passenger carrying rolling stock, including high-speed and very high-speed vehicles, powered and non-powered
- category B-II bogies: for inner and outer suburban passenger carrying vehicles, powered and non-powered
- category B-III bogies: for metro and rapid transit rolling stock, powered and non-powered
- category B-IV bogies: for light rail vehicles and trams
- category B-V bogies: for freight rolling stock with single-stage suspensions
- category B-VI bogies: for freight rolling stock with two-stage suspensions
- category B-VII bogies: for locomotives

Structural requirements of bogie frames

This method enables a satisfactory design of bogie frames and includes design procedures, assessment methods, verification and manufacturing quality requirements. It is limited to the structural requirements of bogie frames, including bolsters and axlebox housings. For the purpose of this document, these terms are taken to include all functional attachments, e.g. damper brackets.

Vehicle gauge

The loading gauge and the proposed body cross section dimensions shall be specified in a form consistent with the analysis methodology that enables acceptance in accordance with EN 15273-2 or an equivalent standard specified by the infrastructure controller.

Example of European vehicle loading gauge

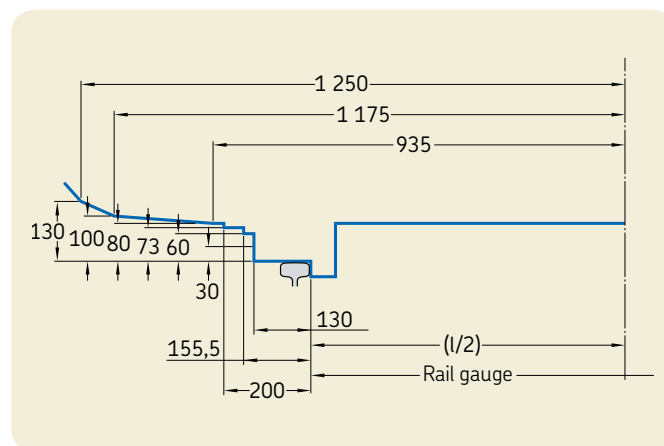

Example of British vehicle loading gauge

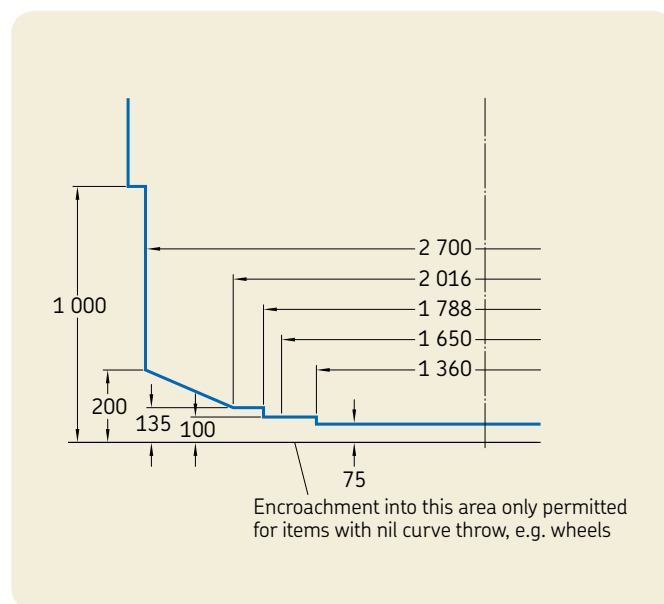

Hotbox detection design requirements

In addition to the SKF Multilog IMx-R bogie condition monitoring systems (→ **chapter 8**), hot axlebox detection (HABD) devices are used. This equipment is mounted stationary on the track and detects the axlebox temperature via infrared measurement. To enable a safe detection, the axlebox design has to consider certain transverse and longitudinal dimensions of the target area.



*Hotbox detection devices installed on the railway track
photo: SCIL AG*

Dimensions and position for the temperature measuring zone (example)

Minimum area on an axlebox that shall remain unobstructed to permit observation by a trackside HABD, is a minimum unbroken length of 50 mm. The 50 mm shall be positioned within the transverse dimensions 1 050 mm and 1 120 mm from the axle centre. A common zone is from 1 070 mm to 1 100 mm. Source: EN 15437-1

Longitudinal dimension on the underside of the axlebox area which has to remain unobstructed to enable observation by a trackside HABD

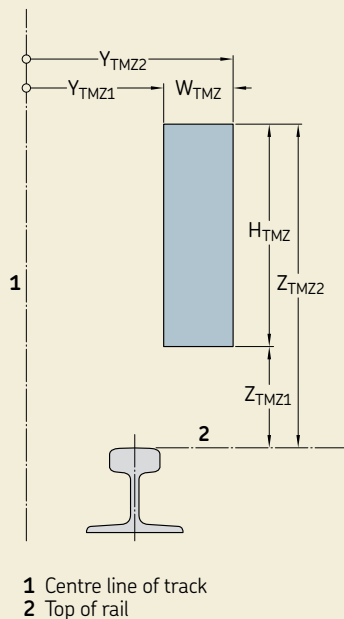

- 1 Centre line of track
- 2 Top of rail

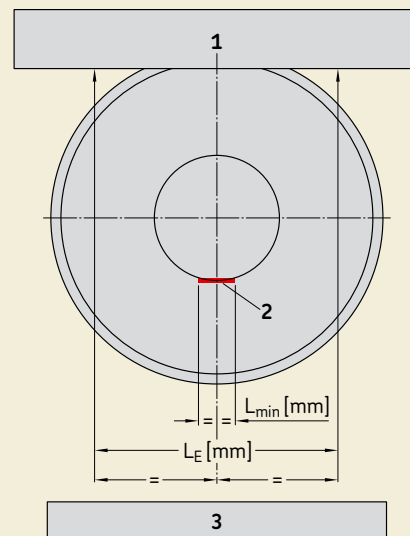

- 1 Zone in which no heat source (unless shielded) that has a temperature greater than that of the bearing or that can influence the temperature of the bearing can be located
- 2 Target area
- 3 Example: $L_E = 500$ mm (minimum length without any influencing heat source), $L_{min} = 100$ mm

Validation

A validation plan covering all intended validation activities and the strategy for demonstrating compliance has to be prepared and must consider the following elements:

- analysis
- laboratory tests
- field tests

The initial validation shows that a design has met all the requirements that have been provided by the associated design documentation and analysis (drawings, calculations, component specifications, tests, etc.).

All software used for theoretical analysis, simulation or the analysis of test data that is submitted as part of the validation process shall have an established pedigree in its field of application or be supported by specific corroboration of its suitability and accuracy.

In the case of an order for a small number of bogies/vehicles, it may not be convenient to justify performing a normal laboratory test programme and/or field testing. However, if these steps are not used as part of the validation, other measures shall be taken to compensate for the lack of testing. This can be done, for example, by using simulation in conjunction with higher safety margins in the design process or by applying more or tighter controls during the maintenance process.

In practice, a design is often a development based on a previously proven design. Where validation evidence from an earlier product is still applicable, it may be used to support the new product or application. The validation plan shall demonstrate how and why the earlier evidence is still applicable and then focus on the validation of the changes. In this context, evidence can be in the form of previous analysis or test results or it can be in the form of accumulated satisfactory service experience.

For small changes, it is not necessary to carry out any further testing, especially if the original analysis and test results agree and give high confidence in the predicted effect of the change, or there is a large reserve of safety, or the detail was not originally considered of sufficient importance to require validation by test.

Proven operating envelope

The proven operating envelope refers to the performance defined by all parameters with maximum and minimum values that are relevant to safety and functionality. The bogie characteristics should include:

- bogie categories
- wheel base
- track gauge
- pivot/axleload
- bogie inertia (z axis)
- wheel diameter
- braking forces
- traction forces
- primary suspension stiffness
- secondary suspension stiffness
- primary vertical damping
- secondary vertical damping
- lateral damping
- anti-yaw damping or rotational torque
- primary clearance
- secondary clearance
- body wheel base/pivot distance
- body mass
- body torsional stiffness
- height of centre of gravity
- body inertia (z axis)
- speed
- cant excess/cant deficiency
- wheel load
- track quality
- a bogie configuration
- one body configuration
- one set of operating conditions

Source: prEN 15827-1:2008, *Bogies and running gear*

Acceptance process flow diagram (informative)

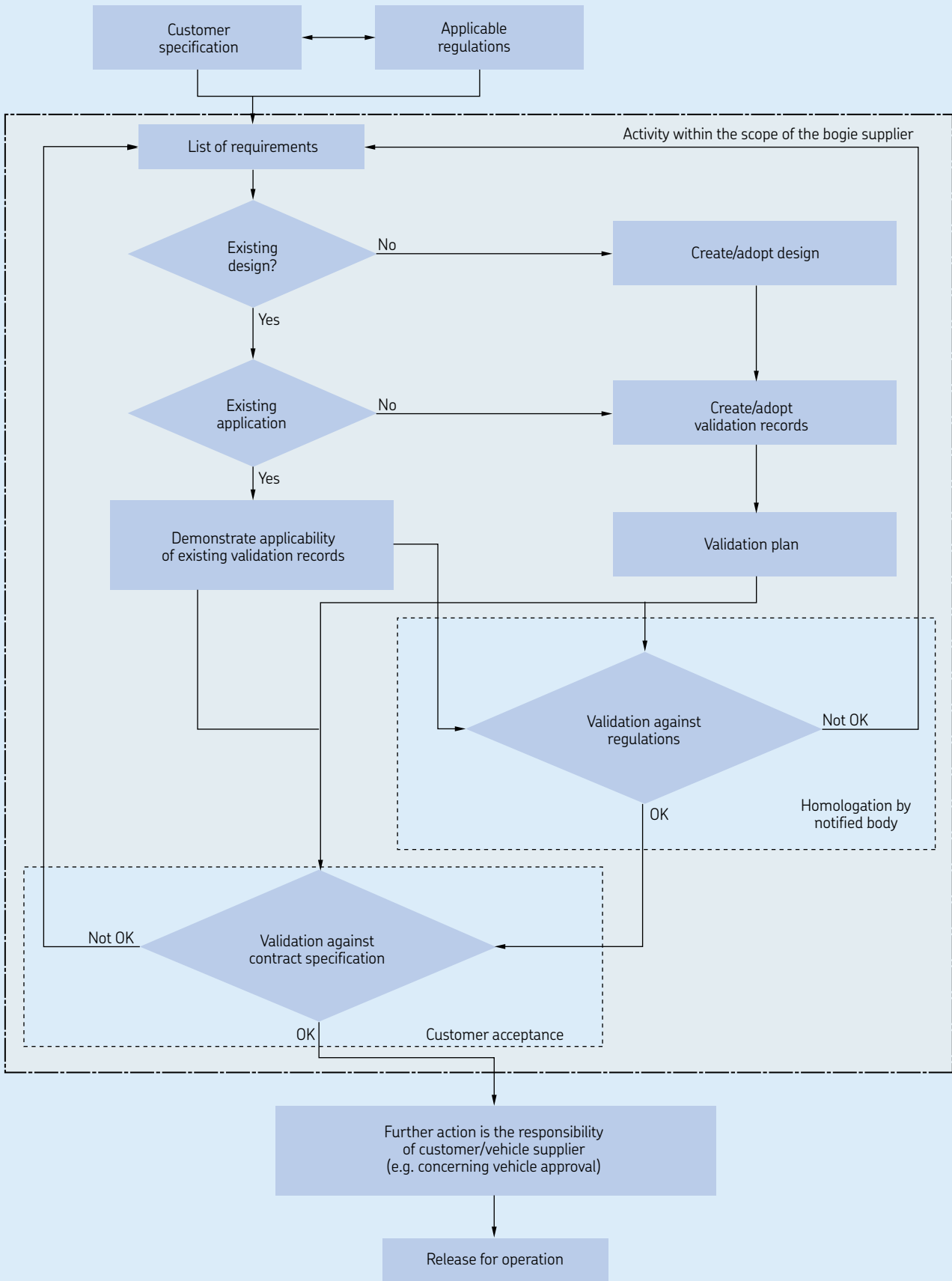

Source: prEN 15827-1:2008, Bogies and running gear

Structural requirements

The structural design of the bogie and running gear shall be based on a complete definition of the loads to be carried. These shall be interpreted to form a set of design load cases. These load cases then define the loading for each structural component.

Vehicle parameters:

- vehicle mass, inertias and centre of gravity, including tolerances
- vehicle configuration/layout
- vehicle body stiffness (especially torsional)
- payload conditions
- wind loads (effective area and centre of pressure)

Bogie/running gear parameters:

- internal system loads (driveline, brake, inertia forces, etc.)
- attachment points
- component masses
- component performance (spring stiffness, damper rates, etc. and tolerances)
- internal loads resulting from assembly/manufacturing

Application and operating envelope:

- track quality
- line characteristics (including depot track): type of track, radii of curves, number of curves, track twist, cant, percentage of distance covered on straight lines and on curves
- operational characteristics: loading cycles, traction cycles, braking cycles, brake control characteristics, wheel slip/slide control, velocity profile, service life/distance run

For design purposes, it is necessary to consider the load cases in two groups, namely:

- the exceptional loads, which are the maximum loads under which the bogie is to remain fully serviceable (and that are used for static strength assessment)
- the fatigue loads that quantify the normal repetitive service loading conditions (and that are used for durability assessment)

Source: prEN 15827-2:2008, *Bogies and running gear*

Exceptional loads

Examples of exceptional operating scenarios:

- maximum (exceptional) payload
- payload application rate (freight wagons)
- exceptional vertical acceleration
- exceptional bogie/vehicle twist
- emergency braking or other exceptional braking conditions
- exceptional component situations (motor short circuit, maximum starting torque, etc., including dynamic effects)
- extreme environmental conditions (extreme temperature changes, wind, etc.)
- heavy shunts
- lateral/roll limit at overturning or at track movement (Prud'homme limit), whichever is the most severe (i.e. gives the worst case of transverse and roll forces acting on the bogie structure)
- exceptional yawing (bogie rotation into stops)
- exceptional steering/lozenging forces due to high wheel adhesion
- exceptional acceleration loading from bogie mounted equipment
- lifting and jacking – in workshop and in service, with or without the bogies attached to the vehicle body
- transportation of bogies
- low speed derailment
- vehicle recovery (re-railing, lifting of a rolled over vehicle, etc.)
- vehicle body mass (dynamic movement)
- load/unload cycles (payload)
- wheel/rail interaction (lozenging, track twist)
- enforced translations and rotations (e.g. shear stiffness of secondary springs when yawing)
- normal acceleration inertia loading acting on mounted equipment and bogies/running gear masses - including consideration of potential resonance problems
- traction
- braking
- damper forces

The way in which the loading is quantified and applied has to correspond with the way in which the permissible stresses are defined. This is particularly important in fatigue analysis; with the endurance limit approach, the stress due to the worst load combinations should be considered, whereas for a cumulative damage approach, the effective stress spectrum due to the combined effect of the load scenarios is required.

Where strength assessments are undertaken using fatigue loads derived from simulations or tests, an appropriate factor shall be included in the analysis to reflect the uncertainty in the design load.

Source: prEN 15827-2:2008, *Bogies and running gear*

Acceptance criteria

This information is based on EN 15827 and prEN 13479:2008. The safety factor incorporated into the design and validation process covers uncertainties in design, manufacturing and validation process, including:

- dimensional tolerances (normally calculations are based on the nominal component dimensions)
- manufacturing process
- analytical accuracy

Safety factor

To determine the appropriate safety factor, the following should be considered:

- consequences of failure
- redundancy
- accessibility for inspection
- level/frequency of quality control
- component failure detection possibility
- maintenance interval

The safety factor, designated S ($\geq 1,0$), is applied when determining utilization. It shall be consistent with the assessment method being used.

When using established methods of analysis that have produced safe designs in the past, the safety factor can be based on this experience. If the methods are conservative in their approach, then the safety factor may be an inherent part of the method and S can be taken as 1,0.

Static strength

Calculation and/or testing is used to make sure that no permanent deformation, instability or fracture of the structure as a whole, or of any individual element, will occur under an exceptional design load. An appropriate failure criterion is chosen for the determination of the stress depending on the type of material. For example, for ductile material, it is common to use the von Mises stress criteria (→ page 64).

In cases where local plasticity occurs, it shall be demonstrated that the functionality and durability of the structure is not impaired under exceptional loads. If the analysis incorporates local stress concentrations, then it is permissible for the theoretical stress to exceed the yield strength or 0,2% proof strength of the material.

The areas of local plastic deformation associated with stress concentrations shall be sufficiently small so as not to cause any significant permanent deformation when the load is removed. The avoidance of significant permanent deformation can be demonstrated by the following approaches, according to this standard.

Fatigue strength

The fatigue strength can be demonstrated by methods like endurance limit approach, cumulative damage approach or other established methods. Fatigue strength can be evaluated using S-N curves, also known as Wöhler curves. These are derived assuming a survival probability of at least 95%.

Endurance limit approach

This approach can be used for areas where all dynamic stress cycles remain below the material endurance limit. Where a material has no defined endurance limit or some repetitive stress cycles exceed the limit, the cumulative damage approach shall be followed. Common standards used for material endurance limit stresses are:

- prEN 1993-1-9:2004, Eurocode 3: Design of steel structures, Part 1.9: Fatigue
- EN 1999-1-2, Eurocode 9: Design of aluminium structures. Structural fire design

The required fatigue strength is demonstrated provided the stress, calculated from all appropriate combinations of the fatigue load cases or measurement results, remains below the endurance limit. It is permissible for stress cycles, due to exceptional loads, to exceed the endurance limit since, by definition, they do not occur frequently enough to significantly affect durability.

Stiffness criteria

Stiffness requirements arise basically in two main areas:

- Deflections under load have to be confined to levels that will not impair functionality.
- Make sure that the stiffness of the bogie structural components and equipment attachments are such that no unacceptable structural resonances occur.

Designs

Principles

In this overview, some current axlebox designs and the wheelset interface are briefly described. This should help in communication, especially in cases where no detailed bogie design is fixed yet. However, axleboxes are customized and a huge number of other designs were applied in the past for different bogie configurations. New bogie design principles will require further design variations or complete new axlebox solutions.

Un-sprung axleboxes

Plummer block housings

For vehicles that operate with very low speeds like in industrial areas such as metal and mining companies, different plummer block housings are used. These housings are attached directly to the frame or to the bogie.

Freight car axleboxes

Main bogie design principles for freight cars are already mentioned see **page 38** and **page 39**. In addition to the 3-piece bogie designs where several designs of adapters are applied, freight car axleboxes are used for European designs. These designs are used by several bogie manufacturers and operators outside Europe as well [13].

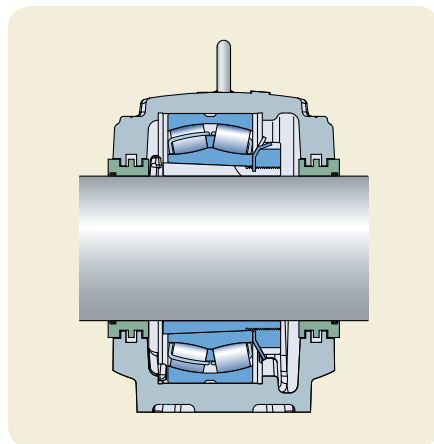

Large SNL plummer block housing incorporating a spherical roller bearing mounted on an adapter sleeve

Design principles of freight car axleboxes

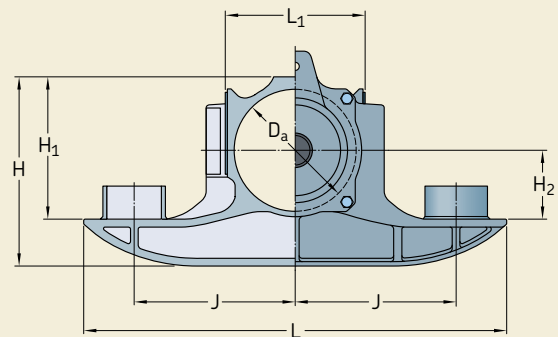

Axlebox for Y25 bogies for 4-axle freight cars

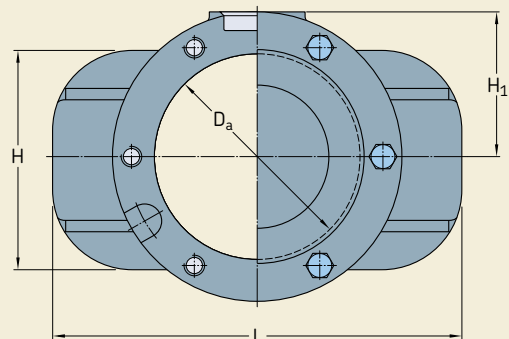

UIC axlebox for 2- and 4-axle freight cars

Axleboxes for locomotive and passenger vehicles

There are basically three axlebox design principles applied to different spring and guidance systems:

- One-piece housings that have to be mounted axially onto the wheelset with the mounted bearing unit.
- Two-piece housings that are split designs. This enables a radial mounting of the axlebox. The main advantage is the ease of dismounting the complete wheelset by unscrewing and removing the upper part of the axlebox. Exchange of wheelsets in workshops is much easier.
- Three-piece housings are split designs as well, but have an additional sleeve to protect the bearing arrangement or unit.

In addition, axlebox designs for rubber spring applications are used. These designs are widely known as Chevron or MEGI designs. The spring supports can be angled either inwards or outwards in accordance with the bogie design. Today, one-piece designs are used. Some older designs, especially for inboard bearing applications, were based on a two-piece design.

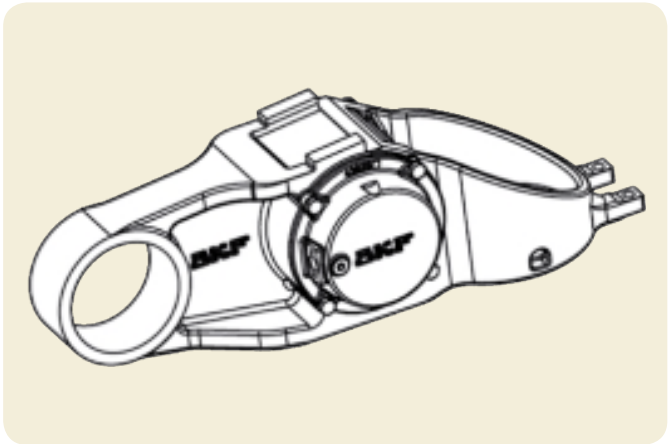

Typical one-piece link arm axlebox design

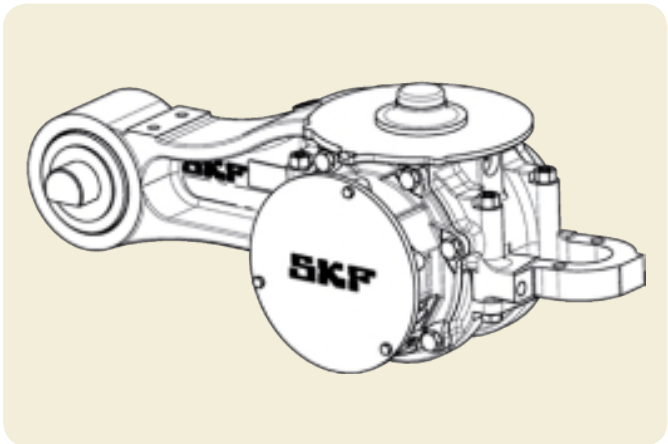

Typical two-piece link arm design

Typical three-piece link arm design

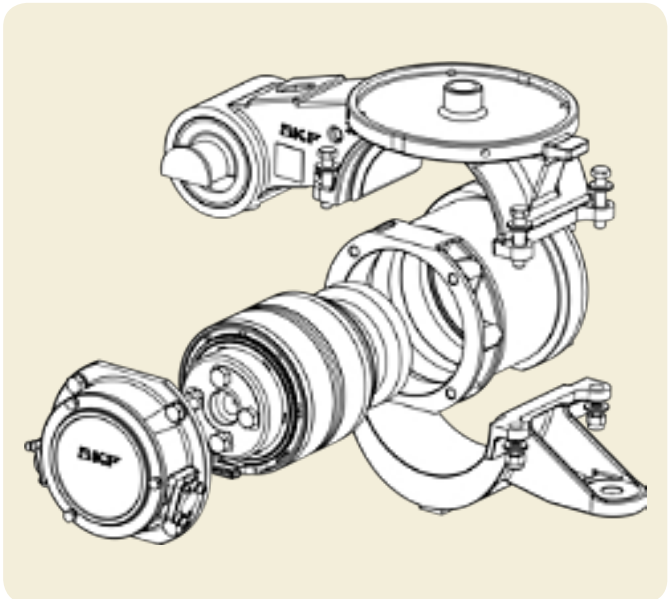

Axlebox assembly including subsystems like axle journal, rubber springs and AXLETRONIC sensor

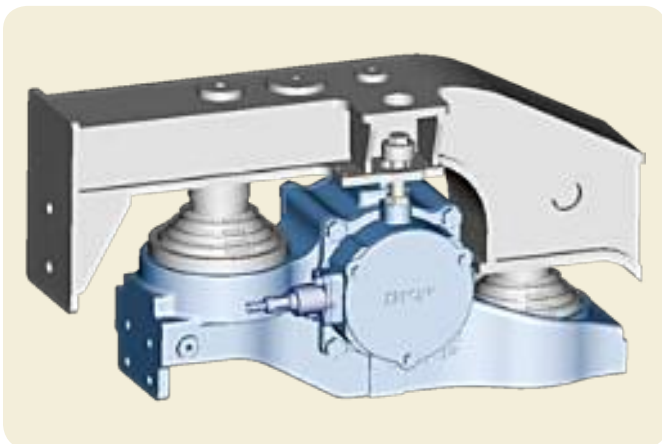

Design principles of locomotive and passenger vehicle axleboxes

One-piece designs

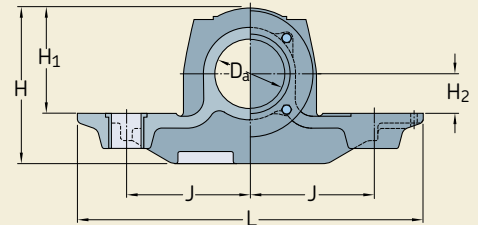
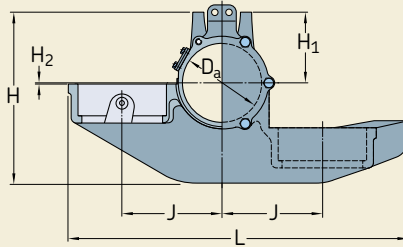
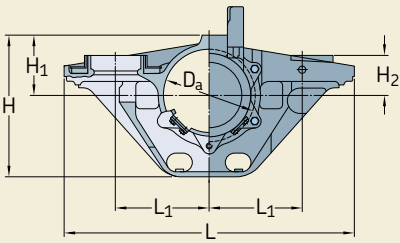

Two off-set helical springs

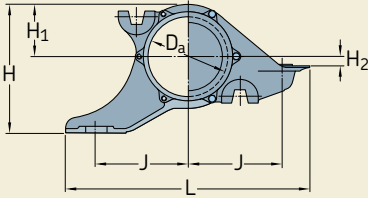

Lemniscate lever guidance

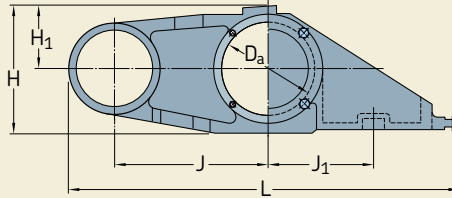

Link arm one-piece design

Two-piece designs

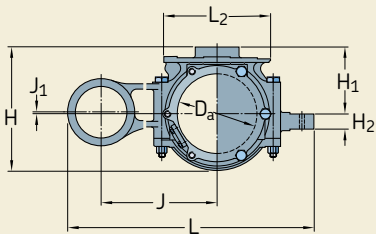

Link arm two-piece design

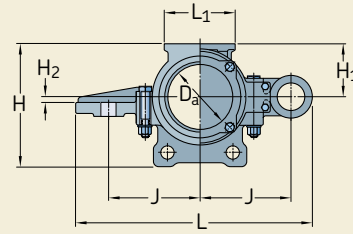

Three-piece designs

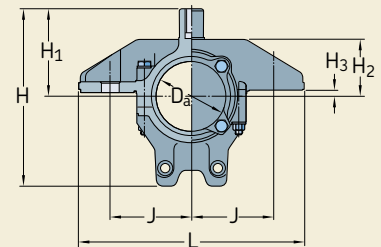
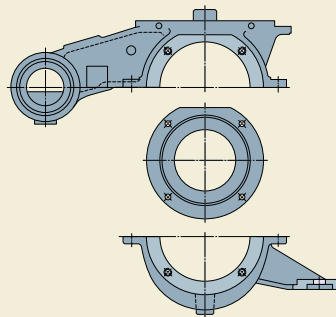
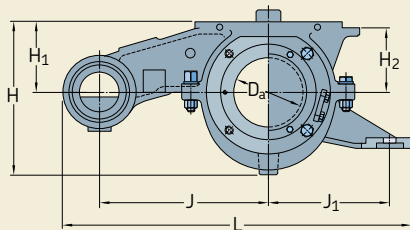

Rubber spring designs

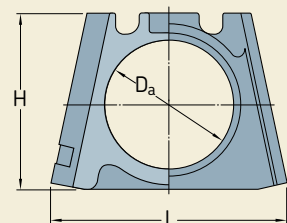

Chevron or MEGI

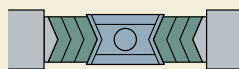

Chevron or MEGI
Spring supports angled inwards

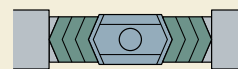

Chevron or MEGI
Spring supports angled outwards

Wheelset geometry

In a case a detailed wheelset drawing is not available at the beginning of a project, the two principle drawings can be used for initial communication between the wheelset supplier and the axlebox designer.

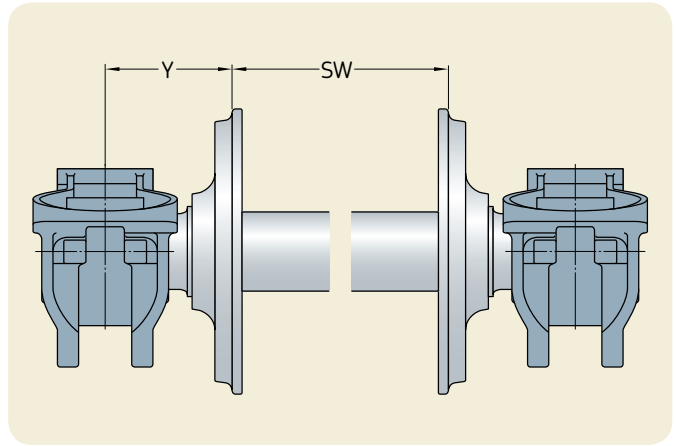

Principles of axial wheelset/axlebox distances

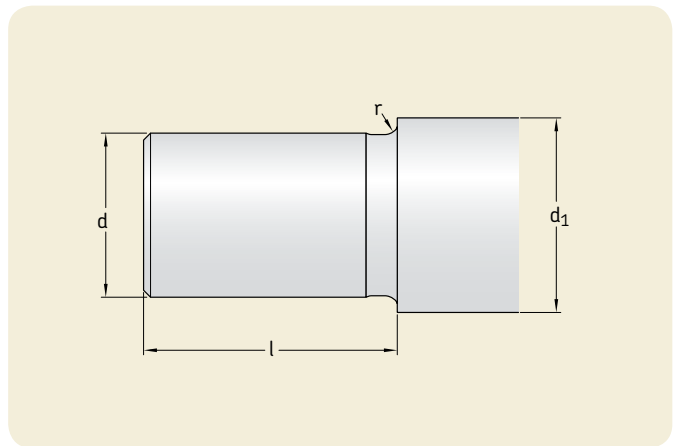

Principal dimensions of an axle journal

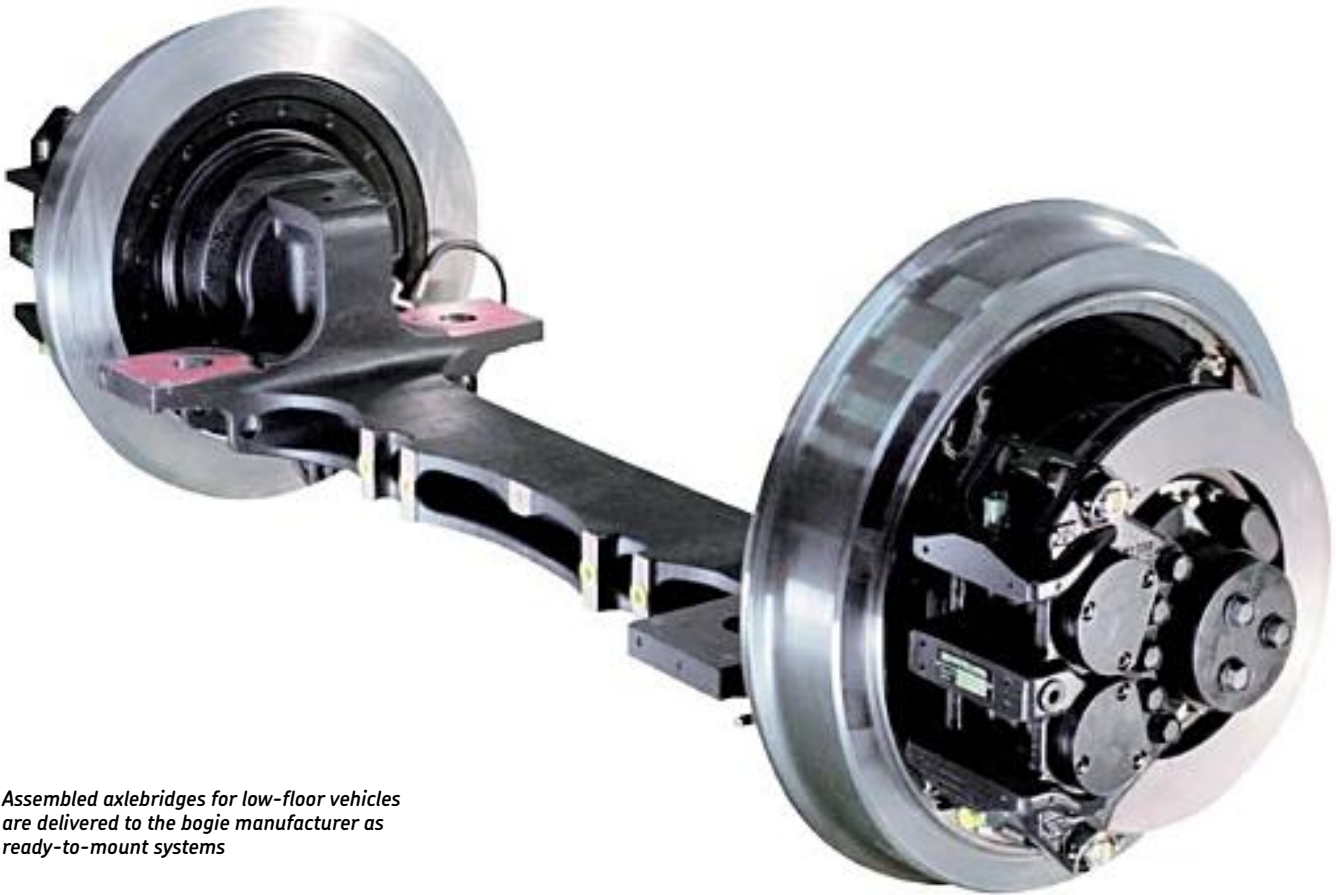

Assembled axlebridges for low-floor vehicles are delivered to the bogie manufacturer as ready-to-mount systems

Axlebridge designs

Axlebridge designs are applied for low-floor vehicles in mass transit operation. There is a very limited space to accommodate propulsion and running gear/bogie components. The axlebridge design connects the two independent wheels and their bearings via a bridge design, which can be seen as a further development of an axlebox housing. This design principle can be applied to motorized and trailer bogies.

The powered running gear is equipped with a hollow shaft, which is connected to the wheel with an elastic spider coupling. The traction torque is transmitted to the wheels from a longitudinal traction motor and a gear drive on both ends.

At the non-powered axle, a flange brake disc is mounted to the wheel with two guiding rods mounted to support the axle during braking. In addition, on the stub axle of both executions (powered and non-powered), a magnetic track brake for emergency braking is mounted.

SKF delivers a ready-to-mount subassembly, including the axlebridge with the integrated bearing system and mounted components such as wheels, couplings, earth return and brake system. This integrated solution provides logistic cost reductions due to fewer components.



SKF axlebridge assembly line where components such as wheels, couplings, earth return and brake systems are mounted

Axlebox accessories

As mentioned on **page 44**, the axlebox can also serve as a carrier for various accessories or auxiliary equipment. In such cases, the standard front cover is replaced by a special cover.

Axleboxes with earth brushes

In electrically powered vehicles or those where electric power is consumed, e.g. by air conditioners or kitchen equipment of restaurant cars, the current has to be conducted back through the rails and must, therefore, flow from the vehicle body into the wheelset. In order to prevent damaging currents from passing through the rolling bearings, appropriate measures must be taken, such as:

- complete insulation of the bearings, for example, from the axlebox itself by rubber suspension, or by using electrically insulated INSOCOAT bearings (suffix VLO241, except for cylindrical roller axlebox bearings where the suffix VA359 replaces VA350)
- provision of an earthing contact, shunt-connected to the bearings, which makes sure that the current density cannot exceed the critical value (→ **page 40**)

In all cases, a contact system is necessary and is generally incorporated in a locking plate at the end of the journal. It must be well-sealed against the bearing grease. The design of the special cover must be adapted to the various types of contact systems.

Axleboxes with wheel slide protection devices

In order to provide short braking distances and to avoid the occurrence of flats, it is essential to prevent the wheels from locking. Wheelsets for passenger coaches, in particular those for higher speeds, are therefore equipped with an anti-skid device and AXLETRONIC sensors on one of the two axleboxes. The special cover is provided with the appropriate support surfaces and holes for the sensors. The devices may be mechanical or electronic.

Axleboxes with speedometers or AXLETRONIC sensors

The speedometer drive is centred on the front cover and connected to the axle via the locking plate at the end of the journal by means of a driving tongue or crankpin.

Axleboxes with a mounting surface for magnetic rail brakes

Railway vehicles used for high-speed operation or in road traffic (tramways) must, for safety reasons, have higher braking retardation than that attainable from the wheel/rail contact alone. Electromagnetic rail brakes, the carrier frames of which must be supported on an unsprung part of the bogie, are mounted between the axles. The axlebox housings are designed with a cast extension to carry the end of the carrier frame. Spacers of tough plastic minimize noise and wear.

Axleboxes with a mounting surface for electric power contact

Because of the shape of the tunnels of underground railways, electric power take-off is generally from a third "live" rail by a sliding contact arm. This arm must also be mounted on an unsprung part of the bogie and the front cover is then designed with a flange to carry the arm. A screw adjustment enables the height of the arm to be set according to the tyre wear.

Axleboxes for generator drive gears

Passenger coaches are often provided with a generator to charge the coach batteries. The bevel gear that provides the drive is given the same attachment flange as the front cover, which it replaces. The locking plate at the end of the journal is combined with a coupling to the gear. In some cases, there is a considerable overhung mass which must be taken into account when designing the housing guides.

Axlebox material examples

	Housing EN-GJS- 400-15	EN-GJS- 400-18 LT	AlSi7Mg0.6	Components such as end caps S235JR S355J0	
Standard	EN 1563	EN 1563	EN 1706	EN 10025	EN 10025
Type	SG iron	SG iron	Light alloy	Steel	Steel
Density (kg/m ³)	7 100	7 100	2 700	7 800	7 800
Yield limit (MPa)	250	240	210	235	355
Ultimate strength (MPa)	400	400	250	340-510	450-680
Young modulus (MPa)	169 000	169 000	71 000	206 000	206 000
Poisson ratio	0,275	0,275	0,33	0,3	0,3
Elongation (%) ¹⁾	15	18	1	17-21	14-18

¹⁾ measuring the percentage of change in length before fracture

Axlebox materials

Axlebox housings and covers are generally manufactured as castings. Depending on application and customer specifications, various materials can be used. For housings, mainly spheroidal cast iron GJS is used. This very ductile iron is also known as nodular cast iron, spheroidal graphite iron, spherulitic graphite cast iron and SG iron. The main advantage is much more flexibility and elasticity due to its nodular graphite inclusions.

In addition to spheroidal cast iron, light alloy is used in specific cases at the customer's request to achieve a lighter design. However, this material is much more expensive. Older designs were based on cast steel material, which is much more difficult to cast and machine than spheroidal graphite iron [14].

Painting

The painting specification contains requirements like colour (RAL), thickness, anti-corrosion, primer/top coat or single coat as well as cosmetic characteristics. Further topics are neutral salt spray, gloss level to enable precise hot box detection. Last, but not least, the painting has to be in accordance with environmental rules.

Packaging

Proper packaging is a further design feature to achieve high quality delivery of axleboxes to the customer. This is a prerequisite to protect the painting during transport and to secure proper assembly. The delivery has to be based on an optimized quantity per delivery batch. For long distance delivery, the packaging includes further requirements like Vapour Corrosion Inhibitor (VCI) protection.



Packaging examples

Project management example

Proposal phase

Project phase

Pre-design
Pre FEM calculation
Sub-supplier investigation
Proposal drawing
Offering

Detailed studies:
– Designs
– Calculation
– Validation
– Production
– Testing
– Delivery

Conceptual process

The conception process is embedded in a complete project management. Based on the customer's specification, a proposal drawing is developed and an offer is prepared. After receiving the customer order, the project phase starts.

Conception process principle

Customer specification



Exceptional load example

Definition of cases	F_x [N]	F_y [N]	F_z [N]
1 Vertical load	-500 370	0	0
2 Transverse load	-500 370	-33 286	0
3 Simulation of track load	-500 370	-33 286	0
4 Longitudinal spanning	-500 370	0	-44 099
5 Vertical shock	-500 370	0	-44 390
6 Simulation of detachment	-511 957	0	-33 943
7 Starting or stopping torque	-500 370	0	-20 925
8 Simulation of braking	-500 370	0	0
9 Inertia forces	-500 370	0	0

Normal service load example

Definition of cases	F_x [N]	F_y [N]	F_z [N]
1 Vertical load	-75 978	0	0
2 roll + steering (level)	-98 772	-21 214	0
3 roll + steering + transverse load (level)	-98 772	-21 214	0
4 roll + steering + transverse load + track load (level)	-98 772	-21 214	0
5 roll + steering (level)	-53 185	-21 214	0
6 roll + steering + transverse load (level)	-53 185	-21 214	0
7 roll + steering + transverse load + track load (level)	-53 185	-21 214	0
8 Longitudinal spanning	-75 978	0	-16 971
9 Simulation of braking	-75 978,45	0	0
10 Inertia forces	-75 978,45	0	0

Customer specification input

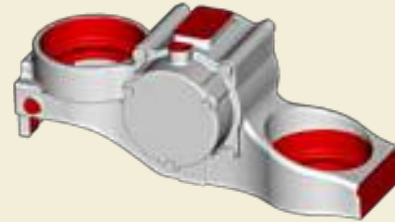

3-D modelling

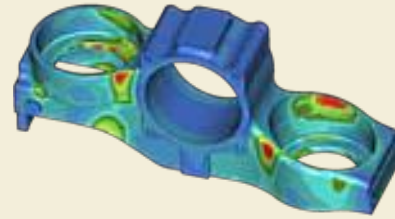

FEM calculation

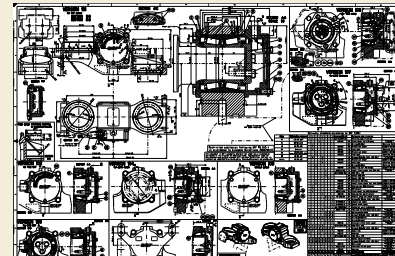

Drawing development



Instruction and report publishing

Calculation

Axlebox calculations are made to check mechanical resistance, deformation and displacement to detect critical areas to be reinforced. Hot box detection availability can be verified with calculations. Another advantage of detailed calculations, is investigating where material can be removed to save weight. Calculation is an important step to validate the design. The results are shared with customers and sub-suppliers for further optimization.

FEM calculation

Finite element method (FEM) calculation is a tool for modal analysis in structural mechanics to determine natural mode shapes. These calculations are done to find approximate solutions of partial differential equations as well as of integral equations. The solution approach is based either on eliminating the differential equation completely (steady state problems), or rendering into an approximating system of ordinary differential equations, which are then numerically integrated using standard techniques such as Euler's method, Runge-Kutta method, etc.¹⁾.

FEM modelling

Based on the customer specification and current standards, like UIC rules and European standards, a loading definition is worked out to cover service requirement and requirements for exceptional cases. The process is mainly based on geometrical data obtained from 3D files or 2D drawings and customer specifications.

After the 3D modelling, first static calculations based on exceptional loads are done. The next step is the fatigue calculation based on service loads, which finishes with the fatigue results and their validation. The main advantage is that this validation step can be done without performing a physical test.

Based on UIC or EN bogie standards, formulas and methodology to define loads and to simulate exceptional and service loading cases are extracted. Prerequisites are detailed data about axleload or mass of vehicles, bogies and unsprung mass suspension stiffness, application parameters, dynamic factors, acceleration of linked components etc.

Extract of rules and minimum results are required, such as safety factors, material yield limit, and number of cycles in fatigue application where 10 million cycles are more or equal to 30 years of operation.

In cooperation with the customer, service load cases are added to the FEM calculation and acting forces are distributed according to the axlebox design. The customer agrees with the final proposition of assumptions before running the calculation.

FEM calculation benefits

- validation of a design and the calculated life
- avoiding testing in many cases, depending on pending customer approval
- optimization tool to achieve the best and most competitive design

Software usage for calculations

3-D modelling	Static calculation of exceptional loads	Fatigue calculation of service loads
PRO-ENGINEER	ANSYS: non-linear contact and geometrics, steady state thermal studies, transient thermal studies etc.	FE-FATIGUE and FEMFAT: using directly ANSYS results, multi-axial stress theory according to Dang Van method
	PRO-MECHANICA: linear calculations, steady state thermal studies	MFC: using directly Pro-M results, multi-axial stress theory according to FKM-guideline

¹⁾ named after Leonhard Euler (1707 – 1783), Carl David Tolmé Runge (1856 – 1927), Martin Wilhelm Kutta (1867 – 1944)

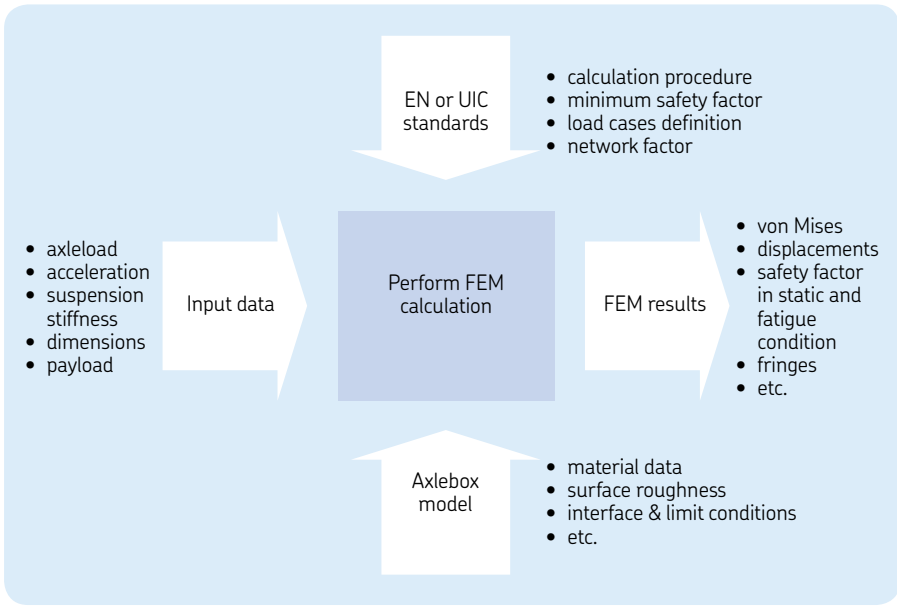

Specification data prerequisites for FEM calculations and potential result portfolio

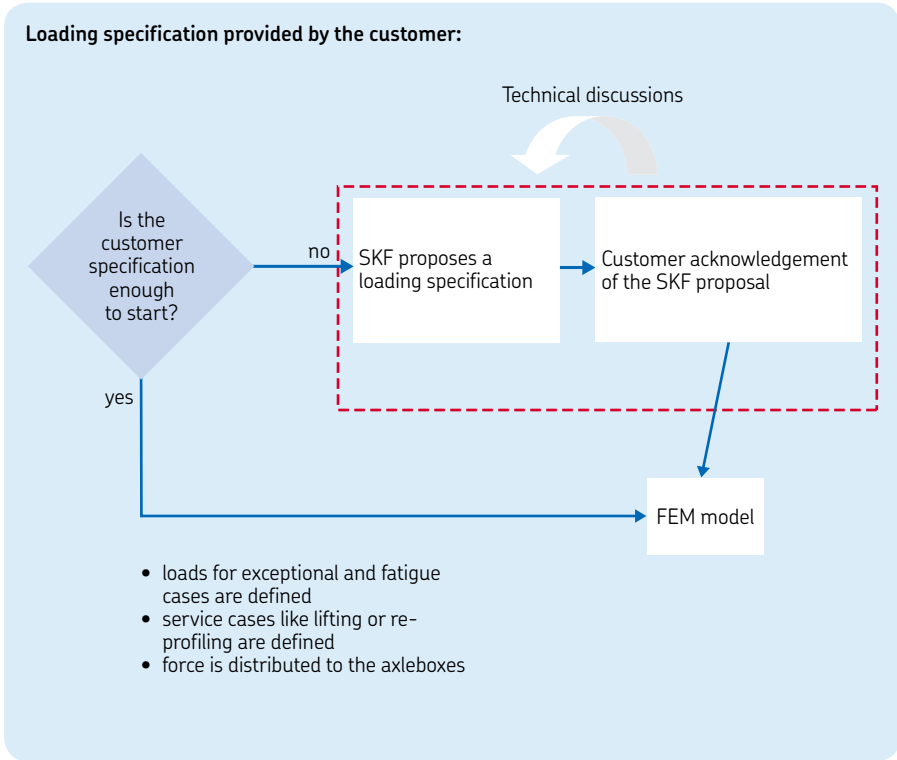

Implementation of the customer specification and/or SKF specification assumptions into the FEM calculation process

FEM calculation results

The FEM results can be provided as max. values based on von Mises¹⁾ or principal stresses.

¹⁾ named after Richard Edler von Mises (1883 – 1953)

Exceptional load example [N]

Definition of cases	F_{zb}	F_{yb}	F_{xb}
1 Vertical load	-106 370		
2 Transverse load	-106 370	-33 286	
3 Simulation of track twist	-106 370	-33 286	
4 Longitudinal lozenging	-106 370		-46 099
5 Verticale shocks	-106 370		-44 390
6 Simulation of derailment	-151 957		
7 Starting or stopping torque	-106 370		-33 943
8 Simulation of braking	-106 370		-20 925
9 Inertia forces	-106 370	0	0

Normal service load example [N]

Definition of cases	F_{zb}	F_{yb}	F_{xt}
1 Vertical load	-75 978		
2 roll + bouncing (maxi)	-98 772		
3 roll + bouncing + transverse load (maxi)	-98 772	-21 214	
4 roll + bouncing + transverse load + track twist (maxi)	-98 772	-21 214	
5 roll + bouncing (mini)	-53 185		
6 roll + bouncing + transverse load (mini)	-53 185	-21 214	
7 roll + bouncing + transverse load + track twist (mini)	-53 185	-21 214	
8 Longitudinal lozenging	-75 978		-16 971
9 Simulation of braking	-75 978		0
10 Inertia forces	-75 978	0	0

Main forces acting on an axlebox

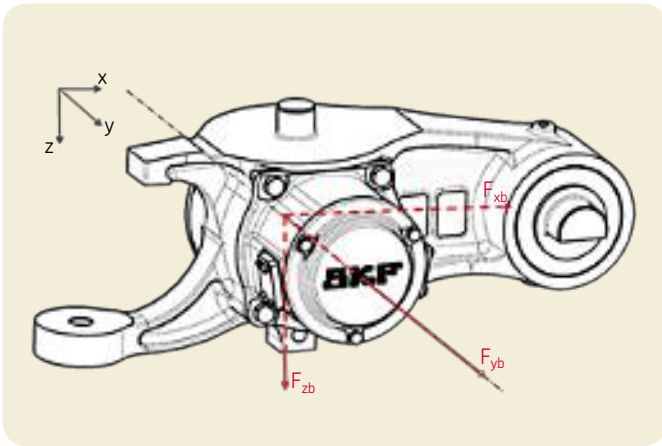

Static exceptional load case example [N]

Case	F_{zp} plate	F_z suspension	F_z bushing	F_y bushing	F_x bushing	F_z reprofiling	F_z wheelset	F_{zd}	F_{yd}	F_{xd}
LCE1-1	47 000	41 602	36 033	-44 141	-15 017	0	0	5 000	-2 000	-1 000
LCE1-2	47 000	70 310	36 033	-44 141	15 017	0	0	5 000	-2 000	1 000
LCE2-1	47 000	61 548	36 033	28 804	24 350	0	0	0	0	0
LCE2-2	47 000	61 548	36 033	-28 804	-24 350	0	0	0	0	0
LCE3	47 000	30 544	36 033	0	-75 414	0	0	0	0	0
LCE4	46 769	0	35 856	0	0	0	0	0	0	0
LCE5	47 000	86 421	36 033	0	6 767	0	0	0	0	0
LCE6	47 000	57 604	36 033	0	-21 932	0	0	0	0	0
LCE7	47 000	97 072	36 033	0	0	0	0	0	0	0
LCE8	28 700	-24 307	-13 393	0	0	0	0	0	0	0
LCE9	28 732	0	49 061	0	0	50 000	0	0	0	0
LCE10	28 732	0	0	0	0	0	-19 953	0	0	0

Fatigue load cases [N]

Case	F_{zp} plate	F_z suspension	F_z bushing	F_y bushing	F_x bushing	F_z reprofiling	F_z wheelset	F_{zd}	F_{yd}	F_{xd}
LCS Max1	8 980	0	6 885	-26 628	-18 558	0	0	2 500	-1 000	-500
LCS Max2	8 980	0	6 885	26 628	18 558	0	0	2 500	1 000	500
LCS Min1	47 000	33 537	36 033	26 628	18 558	0	0	2 500	1 000	500
LCS Min2	47 000	33 537	36 033	-26 628	-18 558	0	0	2 500	-1 000	-500

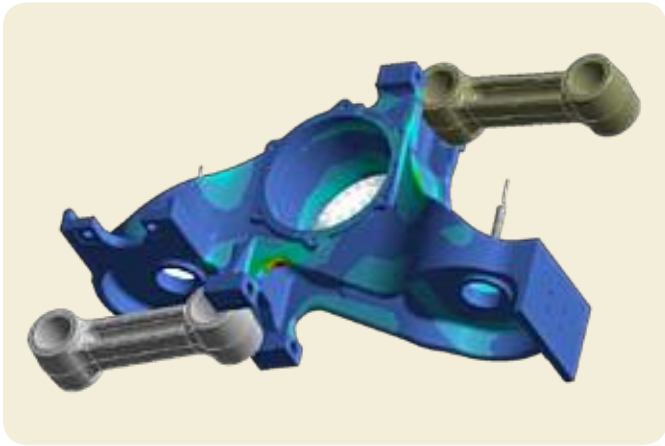

FEM calculation results for a passenger vehicle axlebox

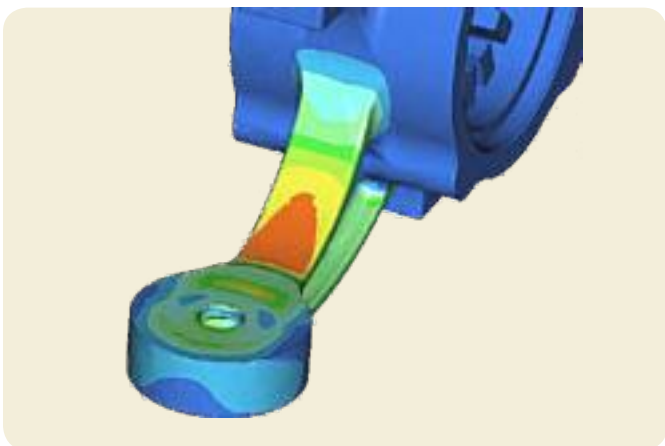

Display of FEM calculation results for an integrated housing arm

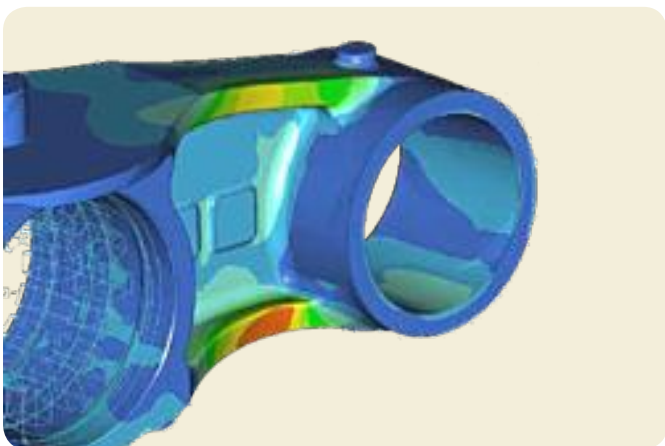

Display of FEM calculation results for a link arm axlebox housing

Fatigue post processing

Based on proven standards and practical experience, like data from the FKM (Forschungskuratorium Maschinenbau) testing institute, statistical post-processing is done. The software uses the fatigue output files (e.g. stress results) to calculate a safety factor. The two load cases that give maximum stress amplitude are further calculated. Several influencing factors, like mean stress, surface condition, and local stress gradient have to be considered. This enables the detection of critical areas that cannot be observed only by FEM calculations.

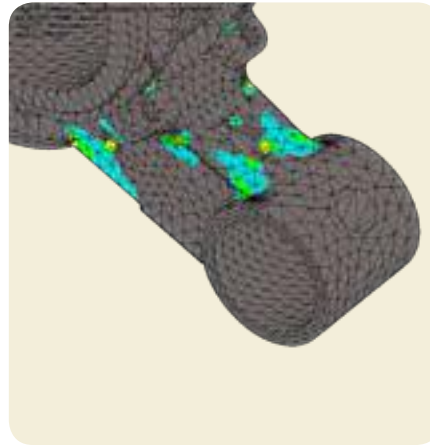

Visualization of the fatigue post processing results

Fatigue post processing input data and menu selection

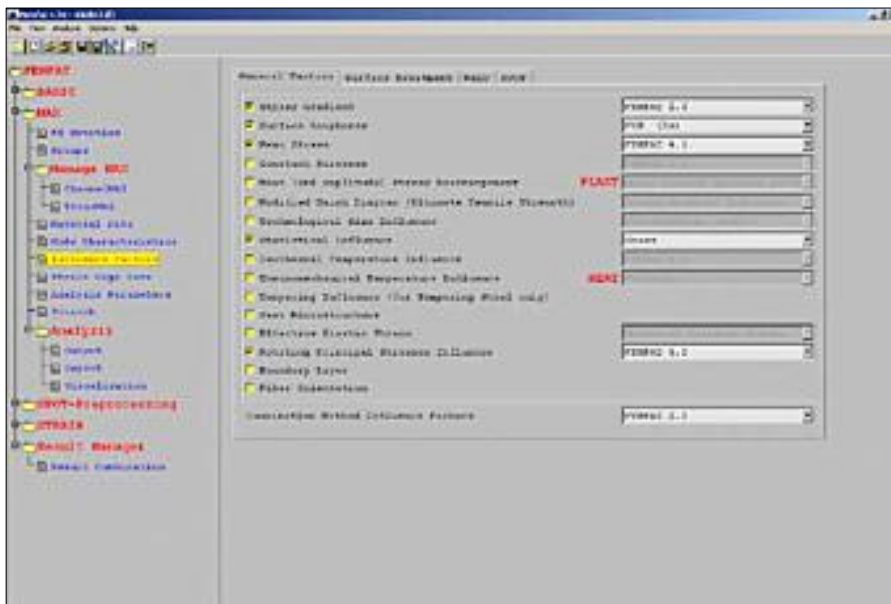

Display of results of the equivalent stress history

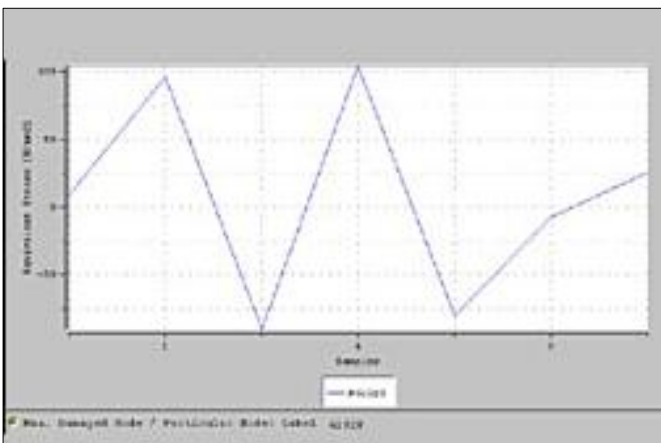

Display of results of calculated combinations of mean and alternating stresses by a Haigh diagram

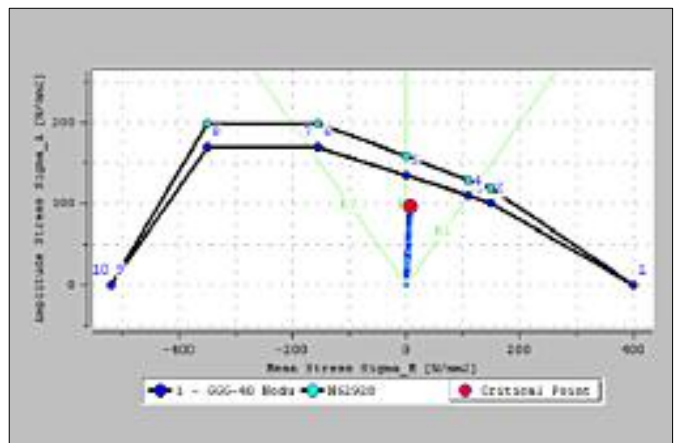

Further FEM capabilities

In addition to load and safety factor calculations, further detailed investigations can be done to validate the performance of the axlebox design. These analyses include thermal, displacement, contact and vibration investigations.

A further application of FEM results is the bolt calculation method based on the VDI 2230 method. This covers a complete procedure investigate into a threaded element subjected to strong loads. The load cases are extracted from application load case specifications.

Main calculation steps are definition of bolt component in regard to dimension and material, axial and radial load input. The force introduction parameter and pre-stress force lost as well as the friction input at the head, thread and interfaces have to be selected. The tightening method, either hydraulic tightening or torque wrench, has to be indicated. The calculation is according the tightening prescription from either yield limit, max. tightening torque or max. assembly pre-stress forces. After computing, the result are displayed with safety factors.

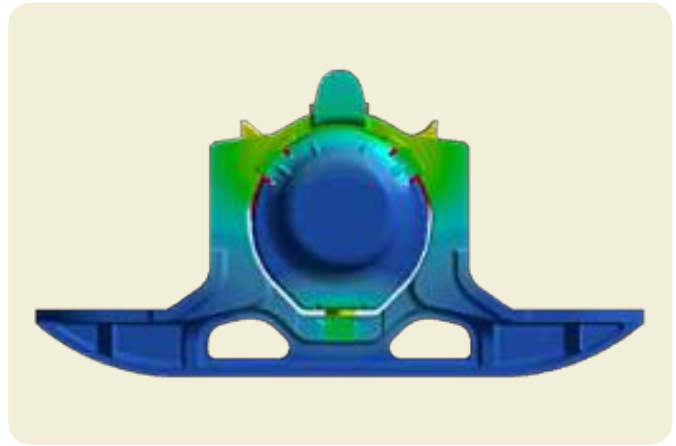

Results of a thermal analysis for a Y25 freight car axlebox

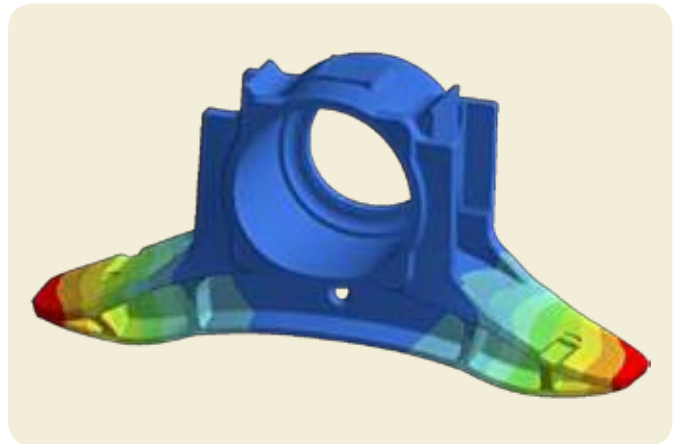

Results of a deformation analysis for a Y25 freight car axlebox

Results of a T-bar vibration analysis for a Y25 freight car axlebox



Results of a contact analysis for a Y25 freight car axlebox

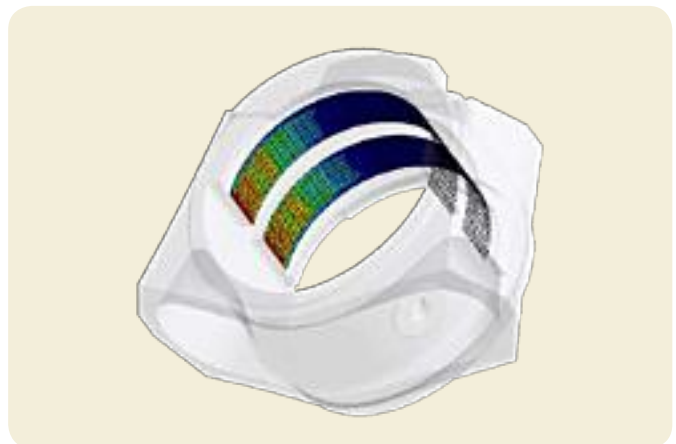

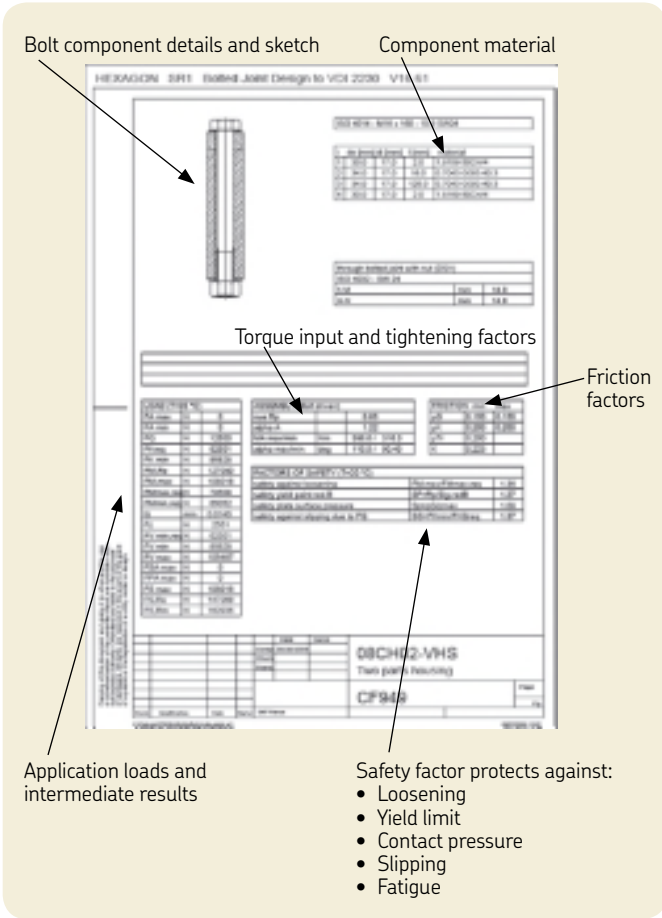

Example of a bolt calculation report

Bolt calculation by FEM simulation is performed to verify the mechanical behaviour of the assembly.

- static linear analysis to verify housing arms acceptable stiffness and behaviour
- static linear analysis also gives input data for bearing calculation
- contact analysis considering bolts joints, impact on covers and contact surface

Assumptions and inputs are made by calculating data according to application static loads as well as stiffness of the simplified bearing correlated with real part measurements.

The output shows the results as stresses, displacement and contact force.

In case of a gap between screwed parts and a certain bending of the components, a detailed FEM calculation has to be done (see illustration below). The VDI 2230 method is only applicable if there is no gap between components.

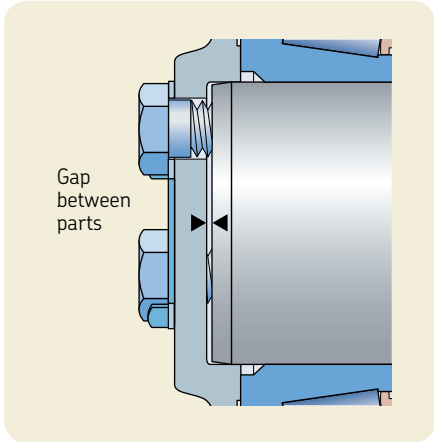

Bolts applied in an axlebox housing, example for calculation

Example of a bolt calculation model set up

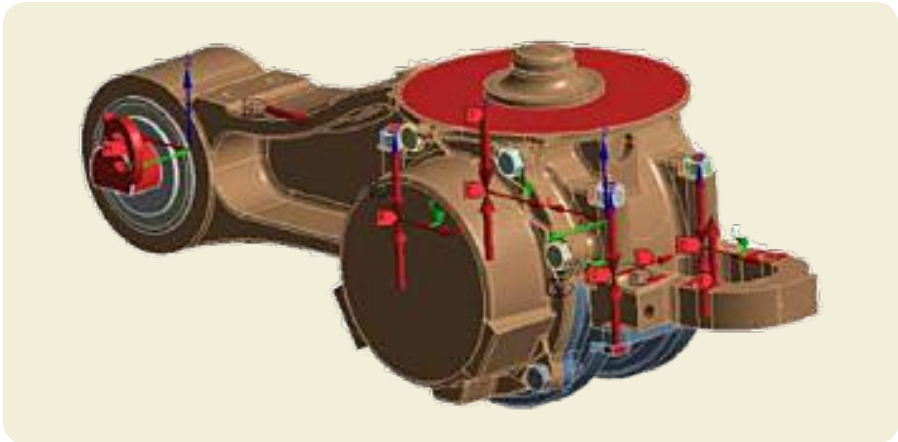

Bolts applied in an axlebox housing



Industrialization

After the design validation and the customer's approval of the results, the industrialization process starts. This process includes manufacturing of patterns, moulding, machining, sometimes welding operations such as to connect guiding plates, painting, assembly, packaging. Delivery is in accordance with the logistical requirements and usually shipped to the customer or the wheelset supplier as a complete package containing the axlebox and bearing units as well as sensor arrangements and other components.

For mounting, SKF offers further services such as mounting by qualified engineers. Alternatively, SKF can either supervise the mounting process by the wheelset supplier or train the local mounting staff of wheelset suppliers (→ [page 195](#)).

Main axlebox industrialization phases



Patterns



Machining



Machined housing



Assembly



Packaging

Testing

In general, SKF axlebox testing is in accordance with UIC 615-4. In addition, specific tests can be done at the customer's request for certain applications.

Static testing

Main features include:

- magnitudes and positions of forces to be applied
- combinations of forces to be applied
- positions and types of measurements to be made (e.g. displacements, strains, types of transducer)
- methods of evaluation and interpretation of measured stresses
- limiting stresses
- any other acceptance criteria

Dynamic testing

Main features include:

- forces to be applied (i.e., static components, quasi-static components, dynamic components) and positions
- combinations of different forces, taking into account the phase relationship of different cyclic forces and their relative frequency
- number of cycles
- positions and types of measurements to be made (e.g. displacements, strains, types of transducer)
- methods of evaluation
- acceptance criteria

This test is based on UIC 615-4 requirements. The load distribution profile calculated according to UIC fatigue load cases. In general, dynamic testing is done with 10 million load cycles and three principal load cases:

- up to 6 million cycles with 100% load profile
- 6 to 8 million cycles with 120% load profile
- 8 to 10 million cycles with 140% load profile

Crack checking is done after each million load cycles. The test is approved if no parts are detected with any cracks.

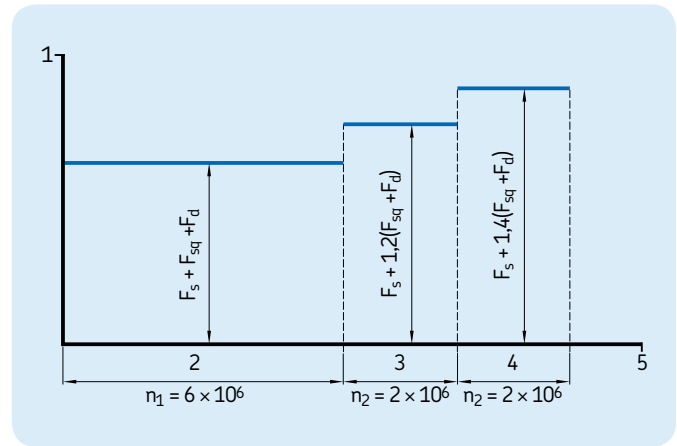

Quasi-static load cycles, normally reversed every 10 to 20 dynamic cycles

- 1 Force magnitude
 - 2 First load sequence
 - 3 Second load sequence
 - 4 Third load sequence
 - 5 Cycles
- Source: prEN 13749:2008

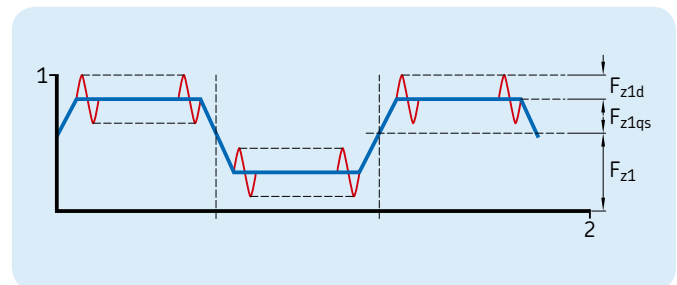

Variation of vertical and transverse forces with respect to time

- 1 Transverse force F_y
 - 2 Time
- Source: prEN 13749:2008



Axlebox equipped with load gauges for validation testing



Application of strain gauges for stress level recording

Fatigue testing of a high-speed axlebox housing



Fatigue testing bench



Example of the correlation of calculated loads based on an axlebox FEM model and measured loads during the laboratory test with a physical axlebox

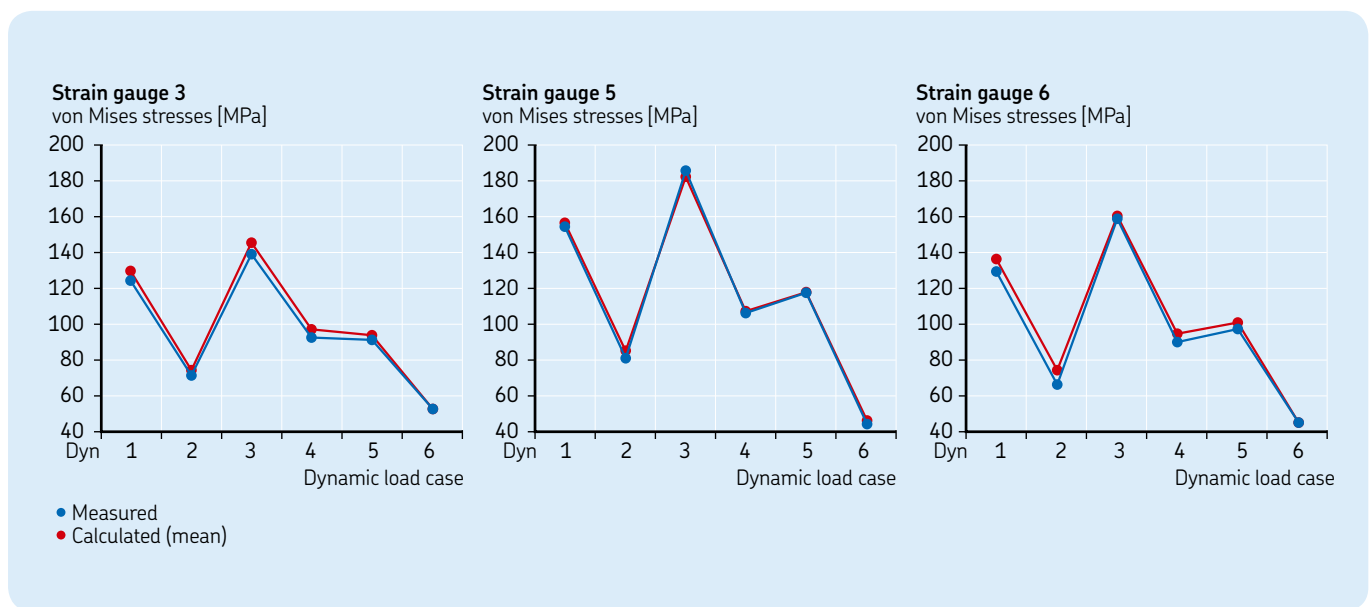

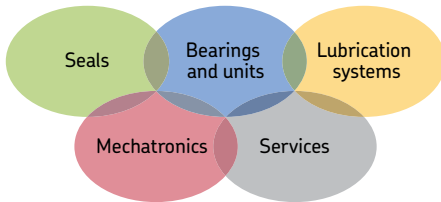

The Power of Knowledge Engineering

Drawing on five areas of competence and application-specific expertise amassed over more than 100 years, SKF brings innovative solutions to OEMs and production facilities in every major industry worldwide. These five competence areas include bearings and units, seals, lubrication systems, mechatronics (combining mechanics and electronics into intelligent systems), and a wide range of services, from 3-D computer modelling to advanced condition monitoring and reliability and asset management systems. A global presence provides SKF customers uniform quality standards and worldwide product availability.

References

- [13] Kuře, G., Charrier, F., Gouel, X.: *New axlebox concept for heavy loads*. SKF Evolution magazine (2005) 4, pp. 24–27.
- [14] Kuře, G.: *Compact and light axlebox solutions*. 2nd International conference on railway bogies. Budapest 1992.

© SKF, AMPEP, @PTITUDE, AXLETRONIC, EASYRAIL, INSOCOAT, MRC, MULTILOG are registered trademarks of the SKF Group.

All other trademarks are the property of their respective owner.

© SKF Group 2012

The contents of this publication are the copyright of the publisher and may not be reproduced (even extracts) unless prior written permission is granted. Every care has been taken to ensure the accuracy of the information contained in this publication but no liability can be accepted for any loss or damage whether direct, indirect or consequential arising out of the use of the information contained herein.

PUB 42/P2 12783 EN · 2012

Certain image(s) used under license from Shutterstock.com

