

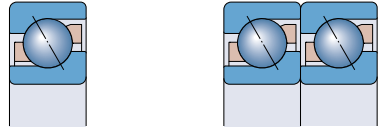

# Angular contact ball bearings



Single row angular contact ball bearings ..... 409



Double row angular contact ball bearings ..... 433



Four-point contact ball bearings ..... 451

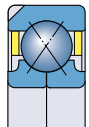

Double row cam rollers ..... 463

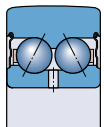

## Angular contact ball bearings

Angular contact ball bearings have raceways in the inner and outer rings that are displaced with respect to each other in the direction of the bearing axis. This means that they are designed to accommodate combined loads, i.e. simultaneously acting radial and axial loads.

The axial load carrying capacity of angular contact ball bearings increases with increasing contact angle. The contact angle is defined as the angle between the line joining the points of contact of the ball and the raceways in the radial plane, along which the load is transmitted from one raceway to another, and a line perpendicular to the bearing axis.

SKF angular contact ball bearings are produced in a wide variety of designs and sizes. Those commonly used in general engineering are

- single row angular contact ball bearings (→ **fig. 1**)
- double row angular contact ball bearings (→ **fig. 2**)
- four-point contact ball bearings (→ **fig. 3**)
- double row cam rollers (→ **fig. 4**).

Detailed information about these bearing and cam rollers belonging to the SKF standard assortment is provided on the following pages.

Fig. 2

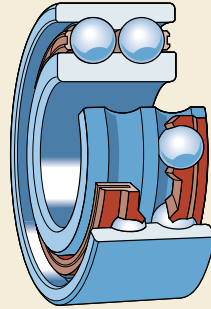

Fig. 3

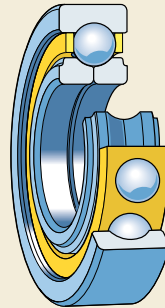

Fig. 1

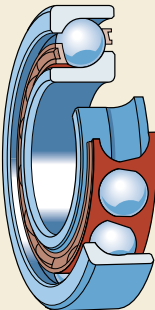
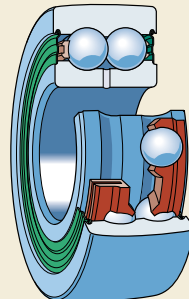

Fig. 4



## Other SKF angular contact ball bearings

Angular contact ball bearings listed in this catalogue constitute the basic SKF assortment and are only part of the total range of SKF angular contact ball bearings. Other products also belonging to the range are briefly described in the following.

### High-precision angular contact ball bearings

The comprehensive range of SKF high-precision angular contact ball bearings covers bearings in three different Dimension Series and a wide range of different design variants. It includes single bearings, universally matchable bearings and matched bearing sets

- without or with low-friction seals
- with three different contact angles
- with steel or ceramic balls
- in standard design (→ **fig. 5**) or high-speed design.

### Fixed section angular contact ball bearings

These bearings have very thin rings and a constant cross section within a particular series, irrespective of the bearing size. They are further characterized by low weight and high stiffness. SKF fixed section bearings (→ **fig. 6**) are inch dimension bearings and available as either open or sealed

- single row angular contact ball bearings
- four-point contact ball bearings

in up to eight different cross sections.

### Hub bearings units

Hub bearings units (HBU) for the automotive industry are based on double row angular contact ball bearings (→ **fig. 7**). They have made an appreciable contribution to the achievement of more compact weight-saving designs, simplified assembly and enhanced reliability.

Detailed information about these products will be supplied on request.

Fig. 5

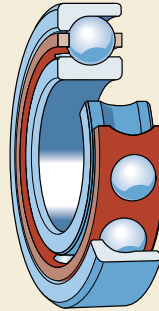

Fig. 6

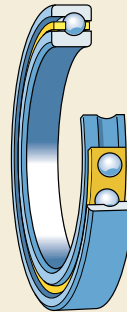
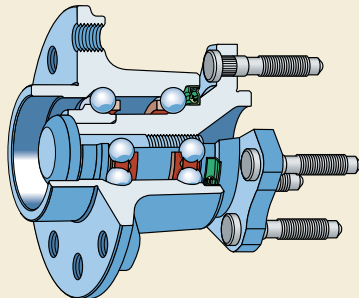

Fig. 7





# Single row angular contact ball bearings

<b>Designs .....</b>	<b>410</b>
Basic design bearings .....	410
Bearings for universal matching.....	410
<b>SKF Explorer class bearings .....</b>	<b>411</b>
<b>Bearing data – general .....</b>	<b>411</b>
Dimensions.....	411
Tolerances.....	411
Internal clearance and preload.....	411
Misalignment.....	413
Influence of operating temperature on bearing material.....	413
Cages.....	413
Speed ratings for bearing pairs .....	413
Load carrying capacity of bearing pairs .....	414
Minimum load.....	414
Equivalent dynamic bearing load.....	415
Equivalent static bearing load.....	415
Determining axial force for bearings mounted singly or paired in tandem.....	415
Supplementary designations.....	417
<b>Design of bearing arrangements .....</b>	<b>418</b>
<b>Product table .....</b>	<b>420</b>

### Designs

A single row angular contact ball bearing can accommodate axial loads acting in one direction only. The bearing is normally adjusted against a second bearing.

The standard assortment of SKF angular contact ball bearings comprises bearings in the 72 B and 73 B series. Two versions are available for different purposes

- basic design bearings (not universally matchable) – can only be used for arrangements with single bearings
- bearings for universal matching.

The bearings have a 40° contact angle (→ **fig. 1**) and therefore can support heavy axial loads. They are non-separable and the bearing rings have one high and one low shoulder. The low shoulder enables a large number of balls to be incorporated in the bearing, thus giving the bearing a relatively high load carrying capacity.

In addition, SKF single row angular contact ball bearings are available in many other dimension series, designs, and sizes. For further information about these bearings, consult the “SKF Interactive Engineering Catalogue” online at [www.skf.com](http://www.skf.com).

#### Basic design bearings

Basic design single row angular contact ball bearings are intended for arrangements where only one bearing is used at each bearing position. They have Normal tolerances concerning bearing width and stand-out of the rings. Therefore, they are not suitable for mounting directly adjacent to each other.

#### Bearings for universal matching

Bearings for universal matching are specifically manufactured so that when mounted in random order, but immediately adjacent to each other, a given internal clearance or preload and/or an even load distribution will be obtained without the use of shims or similar devices. Universally matchable bearings carry a designation suffix to indicate the internal clearance (CA, CB, CC) or preload (GA, GB, GC) of a set of two, prior to mounting.

When ordering, it is necessary to state the number of individual bearings required and not the number of sets.

Paired mounting (→ **fig. 2**) is used when the load carrying capacity of a single bearing is inadequate (tandem arrangement) or when combined or axial loads act in both directions (back-to-back and face-to-face arrangements).

When arranged in tandem (**a**) the load lines are parallel and the radial and axial loads are equally shared by the bearings. However, the bearing set can only accommodate axial loads acting in one direction. If axial loads act in the opposite direction, or if combined loads are present, a third bearing adjusted against the tandem pair must be added.

The load lines of bearings arranged back-to-back (**b**) diverge towards the bearing axis. Axial loads acting in both directions can be accommodated, but only by one bearing in each direction. Bearings mounted back-to-back provide a relatively stiff bearing arrangement that can also accommodate tilting moments.

The load lines of bearings mounted face-to-face (**c**) converge towards the bearing axis. Axial loads acting in both directions can be accommodated, but only by one bearing in each direction. This arrangement is not as stiff as the back-to-back arrangement and is less suitable for the accommodation of tilting moments.

Bearings for universal matching can also be beneficial in arrangements with single bearings. Most bearings are SKF Explorer and as such have higher precision, increased carrying capacity and speed capability.

Fig. 1

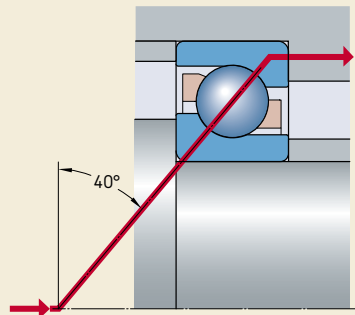

## SKF Explorer class bearings

High performance SKF Explorer angular contact ball bearings are shown with an asterisk in the product table. SKF Explorer bearings retain the designation of the earlier standard bearings, e.g. 7208 BECBP. However, each bearing and its box are marked with the name "EXPLORER".

## Bearing data – general

### Dimensions

The boundary dimensions of SKF single row angular contact ball bearings are in accordance with ISO 15:1998.

### Tolerances

Basic design SKF single row angular contact ball bearings for single mounting are produced to Normal tolerances. Standard design universally matchable bearings are manufactured to better than Normal tolerances.

SKF Explorer angular contact ball bearings are manufactured only as bearings for universal matching with P6 dimensional accuracy and P5 running accuracy.

The values for tolerances correspond to ISO 492:2002 and can be found in **tables 3 to 5**, starting on **page 125**.

### Internal clearance and preload

Internal clearance in single row angular contact ball bearings is only obtained after mounting and is dependent on adjustment against a second bearing, which provides axial location in the opposite direction.

SKF universally matchable bearings are produced in three different clearance and preload classes each. The classes for bearing sets with clearance are

- CA – smaller than Normal axial clearance
- CB – Normal axial clearance (standard)
- CC – larger than Normal axial clearance.

Bearings to clearance class CB are standard. The availability of bearings to other clearance classes can be obtained from **matrix 1** on **page 419**. SKF universally matchable bearings with clearance can be combined in sets of any number of bearings.

The classes for bearing sets with preload are

- GA – light preload (standard)
- GB – moderate preload
- GC – heavy preload.

Bearings to GA class preload are standard (→ **matrix 1** on **page 419**). Bearings with preload can only be paired in sets of two bearings, in contrast to the SKF universally matchable bearings with clearance, as otherwise the preload would increase.

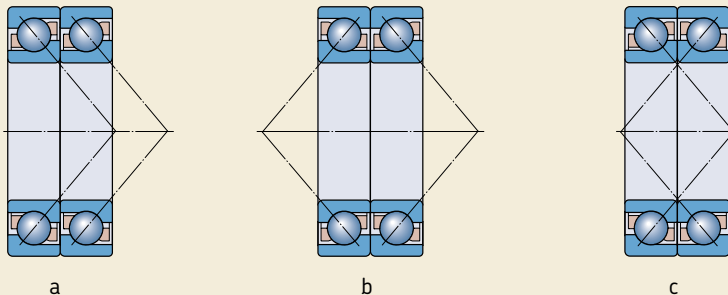

Fig. 2

## Single row angular contact ball bearings

The values for the clearance classes are provided in **table 1** and for the preload classes in **table 2**. The values apply to unmounted bearing sets, arranged back-to-back or face-to-face, and in case of clearance to zero measuring loads.

**Table 1**

**Axial internal clearance of universally matchable single row angular contact ball bearings arranged back-to-back or face-to-face**

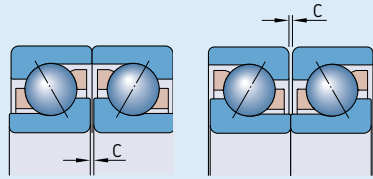

Bore diameter d		Axial internal clearance Class					
		CA		CB		CC	
over	incl.	min	max	min	max	min	max
mm		µm					
<b>10</b>	<b>18</b>	5	13	15	23	24	32
<b>18</b>	<b>30</b>	7	15	18	26	32	40
<b>30</b>	<b>50</b>	9	17	22	30	40	48
<b>50</b>	<b>80</b>	11	23	26	38	48	60
<b>80</b>	<b>120</b>	14	26	32	44	55	67
<b>120</b>	<b>180</b>	17	29	35	47	62	74
<b>180</b>	<b>250</b>	21	37	45	61	74	90

**Table 2**

**Preload of universally matchable single row angular contact ball bearings arranged back-to-back or face-to-face**

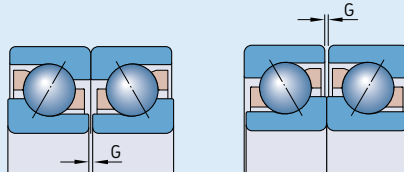

Bore diameter d		Preload Class GA				GB				GC			
		min	max	max	max	min	max	min	max	min	max	min	max
over	incl.	µm				µm				µm			
mm		N				N				N			
<b>10</b>	<b>18</b>	+4	-4	80	-2	-10	30	330	-8	-16	230	660	
<b>18</b>	<b>30</b>	+4	-4	120	-2	-10	40	480	-8	-16	340	970	
<b>30</b>	<b>50</b>	+4	-4	160	-2	-10	60	630	-8	-16	450	1 280	
<b>50</b>	<b>80</b>	+6	-6	380	-3	-15	140	1 500	-12	-24	1 080	3 050	
<b>80</b>	<b>120</b>	+6	-6	410	-3	-15	150	1 600	-12	-24	1 150	3 250	
<b>120</b>	<b>180</b>	+6	-6	540	-3	-15	200	2 150	-12	-24	1 500	4 300	
<b>180</b>	<b>250</b>	+8	-8	940	-4	-20	330	3 700	-16	-32	2 650	7 500	

## Misalignment

Single row angular contact ball bearings have only limited ability to accommodate misalignment. The permissible misalignment of the shaft relative to the housing that will not produce inadmissibly heavy additional forces, depends on the operating clearance in the bearing, bearing size, internal design and the forces and moments acting on the bearing. Because of the complex relationship between the influencing factors, it is not possible to quote any values that are universally valid.

For bearings mounted in sets, particularly those with small axial internal clearance mounted in a back-to-back arrangement, misalignment can only be accommodated by increased ball loads, which will create cage stresses and reduce bearing service life. Any misalignment of the bearing rings will also lead to increased running noise.

## Influence of operating temperature on bearing material

SKF angular contact ball bearings undergo a special heat treatment. When fitted with a steel, brass or PEEK cage, they can operate at temperatures of up to +150 °C.

## Cages

Depending on the bearing series and size, SKF single row angular contact ball bearings are fitted as standard with one of the following cages (→ fig. 3)

- an injection moulded window-type cage of glass fibre reinforced polyamide 6,6, ball centred, designation suffix P (a)
- an injection moulded window-type cage of glass fibre reinforced polyetheretherketone (PEEK), ball centred, designation suffix PH
- a pressed window-type brass cage, ball centred, designation suffix Y (b)
- a machined window-type brass cage, ball centred, designation suffix M (c).

The available SKF standard assortment is shown in **matrix 1** on **page 419**. If bearings with a PEEK cage are required other than listed, please consult SKF.

Bearings having a pressed window-type steel cage, designation suffix J, or a machined

window-type steel cage, designation suffix F, may also be available. Please check availability prior to ordering.

## Note

Bearings with polyamide 6,6 cages can be operated at temperatures up to +120 °C. The lubricants generally used for rolling bearings do not have a detrimental effect on cage properties, with the exception of a few synthetic oils and greases with a synthetic oil base, and lubricants containing a high proportion of EP additives when used at high temperatures.

For detailed information about the temperature resistance and the applicability of cages, please refer to the section “Cage materials”, starting on **page 140**.

## Speed ratings for bearing pairs

For bearings arranged in pairs, the reference speeds provided in the product table for single bearings should be reduced by approximately 20 %.

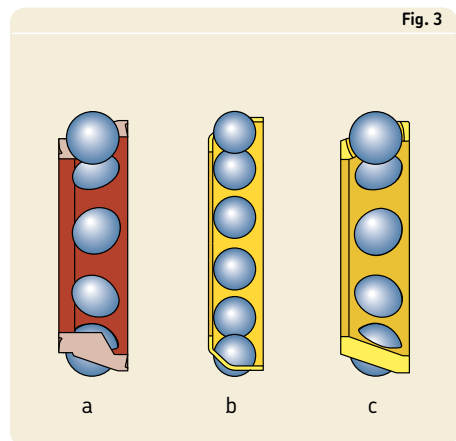

## Single row angular contact ball bearings

### Load carrying capacity of bearing pairs

The values for basic load ratings and fatigue load limits provided in the product table apply to single bearings. For bearing pairs mounted immediately adjacent to each other the following values apply

- basic dynamic load rating for standard bearings in all arrangements and for SKF Explorer bearings in back-to-back or face-to-face arrangement

$$C = 1,62 \times C_{\text{single bearing}}$$

- basic dynamic load rating for SKF Explorer bearings in tandem arrangement

$$C = 2 \times C_{\text{single bearing}}$$

- basic static load rating

$$C_0 = 2 \times C_{0 \text{ single bearing}}$$

- fatigue load limit

$$P_u = 2 \times P_{u \text{ single bearing}}$$

### Minimum load

In order to provide satisfactory operation, angular contact ball bearings, like all ball and roller bearings, must always be subjected to a given minimum load, particularly if they are to operate at high speeds or are subjected to high accelerations or rapid changes in the direction of load. Under such conditions, the inertia forces of the balls and cage, and the friction in the lubricant, have a detrimental influence on the rolling conditions in the bearing arrangement and may cause damaging sliding movements to occur between the balls and raceways.

The requisite minimum load to be applied to single bearings and bearing pairs arranged in tandem can be estimated using

$$F_{\text{am}} = k_a \frac{C_0}{1\,000} \left( \frac{n d_m}{100\,000} \right)^2$$

and for bearing pairs arranged back-to-back or face-to-face from

$$F_{\text{rm}} = k_r \left( \frac{v n}{1\,000} \right)^{2/3} \left( \frac{d_m}{100} \right)^2$$

Table 3

Bearing series	Minimum load factors	
	$k_a$	$k_r$
72 BE	1,4	0,095
72 B	1,2	0,08
73 BE	1,6	0,1
73 B	1,4	0,09

where

$F_{\text{am}}$  = minimum axial load, kN

$F_{\text{rm}}$  = minimum radial load, kN

$C_0$  = basic static load rating of single bearing, or bearing pair, kN (→ product table)

$k_a$  = minimum axial load factor according to **table 3**

$k_r$  = minimum radial load factor according to **table 3**

$v$  = oil viscosity at operating temperature,  $\text{mm}^2/\text{s}$

$n$  = rotational speed, r/min

$d_m$  = bearing mean diameter  
= 0,5 (d + D), mm

When starting up at low temperatures or when the lubricant is highly viscous, even greater minimum loads may be required. The weight of the components supported by the bearing, together with external forces, generally exceeds the requisite minimum load. If this is not the case, the angular contact ball bearing must be subjected to an additional load. Single bearings and bearing pairs arranged in tandem can be axially preloaded by adjusting the inner or outer rings against each other, or by using springs.

### Equivalent dynamic bearing load

For single bearings and bearings paired in tandem

$$P = F_r \quad \text{when } F_a/F_r \leq 1,14$$
$$P = 0,35 F_r + 0,57 F_a \quad \text{when } F_a/F_r > 1,14$$

When determining the axial force  $F_a$ , reference should be made to the section "Determining axial force for bearings mounted singly or paired in tandem".

For bearings mounted in pairs, arranged back-to-back or face-to-face

$$P = F_r + 0,55 F_a \quad \text{when } F_a/F_r \leq 1,14$$
$$P = 0,57 F_r + 0,93 F_a \quad \text{when } F_a/F_r > 1,14$$

$F_r$  and  $F_a$  are the forces acting on the bearing pair.

### Equivalent static bearing load

For single bearings and bearings paired in tandem

$$P_0 = 0,5 F_r + 0,26 F_a$$

If  $P_0 < F_r$ , then  $P_0 = F_r$  should be used. When determining the axial force  $F_a$  reference should be made to the section "Determining axial force for bearings mounted singly or paired in tandem".

For bearings mounted in pairs, arranged back-to-back or face-to-face

$$P_0 = F_r + 0,52 F_a$$

$F_r$  and  $F_a$  are the forces acting on the bearing pair.

### Determining axial force for bearings mounted singly or paired in tandem

When a radial load is applied, the load is transmitted from one raceway to the other at an angle to the bearing axis and an internal axial force will be induced in single row angular contact ball bearings. This must be considered when calculating the equivalent bearing loads for bearing arrangements consisting of two single bearings and/or bearing pairs arranged in tandem.

The necessary equations are provided in **table 4, page 416**, for the various bearing arrangements and load cases. The equations are only valid if the bearings are adjusted against each other to practically zero clearance, but without any preload. In the arrangements shown, bearing A is subjected to a radial load  $F_{rA}$  and bearing B to a radial load  $F_{rB}$ . Both  $F_{rA}$  and  $F_{rB}$  are always considered positive, even when they act in the direction opposite to that shown in the figures. The radial loads act at the pressure centres of the bearings (see dimension a in the product table).

### Variable R

The variable R from **table 4** takes into account the contact conditions inside the bearing. The values for R can be obtained from **diagram 1, page 417**, as a function of the ratio  $K_a/C$ .  $K_a$  is the external axial load acting on the shaft or on the housing and C is the basic dynamic load rating of the bearing, which must accommodate the external axial load. For  $K_a = 0$  use  $R = 1$ .

Table 4

Axial loading of bearing arrangements incorporating two single row B or BE design angular contact ball bearings and/or bearing pairs in tandem

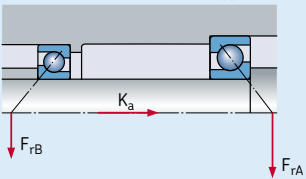
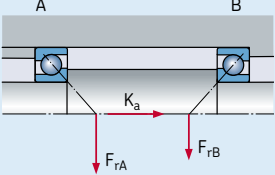
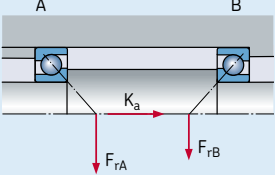
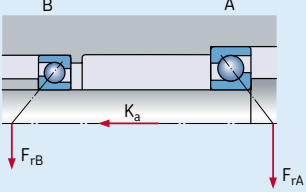
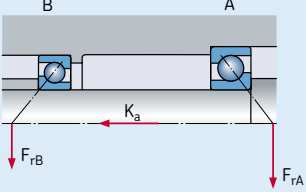
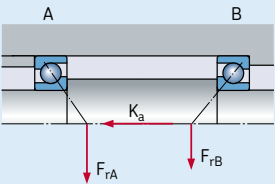
Bearing arrangement	Load case	Axial forces	
<p>Back-to-back</p> 	<p><b>Case 1a</b></p> $F_{rA} \geq F_{rB}$ $K_a \geq 0$	$F_{aA} = R F_{rA}$	$F_{aB} = F_{aA} + K_a$
<p>Face-to-face</p> 	<p><b>Case 1b</b></p> $F_{rA} < F_{rB}$ $K_a \geq R (F_{rB} - F_{rA})$	$F_{aA} = R F_{rA}$	$F_{aB} = F_{aA} + K_a$
<p>Face-to-face</p> 	<p><b>Case 1c</b></p> $F_{rA} < F_{rB}$ $K_a < R (F_{rB} - F_{rA})$	$F_{aA} = F_{aB} - K_a$	$F_{aB} = R F_{rB}$
<p>Back-to-back</p> 	<p><b>Case 2a</b></p> $F_{rA} \leq F_{rB}$ $K_a \geq 0$	$F_{aA} = F_{aB} + K_a$	$F_{aB} = R F_{rB}$
<p>Back-to-back</p> 	<p><b>Case 2b</b></p> $F_{rA} > F_{rB}$ $K_a \geq R (F_{rA} - F_{rB})$	$F_{aA} = F_{aB} + K_a$	$F_{aB} = R F_{rB}$
<p>Face-to-face</p> 	<p><b>Case 2c</b></p> $F_{rA} > F_{rB}$ $K_a < R (F_{rA} - F_{rB})$	$F_{aA} = R F_{rA}$	$F_{aB} = F_{aA} - K_a$

## Supplementary designations

The designation suffixes used to identify certain features of SKF single row angular contact ball bearings are explained in the following.

<b>A</b>	30° contact angle	<b>GB</b>	Bearing for universal matching. Two bearings arranged back-to-back or face-to-face will have a moderate preload before mounting
<b>AC</b>	25° contact angle	<b>GC</b>	Bearing for universal matching. Two bearings arranged back-to-back or face-to-face will have a heavy preload before mounting
<b>B</b>	40° contact angle	<b>J</b>	Pressed window-type steel cage, ball centred
<b>CA</b>	Bearing for universal matching. Two bearings arranged back-to-back or face-to-face will have an axial internal clearance smaller than Normal (CB) before mounting	<b>M</b>	Machined window-type brass cage, ball centred, different designs are identified by a figure, e.g. M1
<b>CB</b>	Bearing for universal matching. Two bearings arranged back-to-back or face-to-face will have a Normal axial internal clearance before mounting	<b>N1</b>	One locating slot (notch) in the large outer ring side face
<b>CC</b>	Bearing for universal matching. Two bearings arranged back-to-back or face-to-face will have an axial internal clearance greater than Normal (CB) before mounting	<b>N2</b>	Two locating slots (notches), 180° apart, in the large outer ring side face
<b>DB</b>	Two bearings matched back-to-back	<b>P</b>	Injection moulded window-type cage of glass fibre reinforced polyamide 6,6, ball centred
<b>DF</b>	Two bearings matched face-to-face	<b>PH</b>	Injection moulded window-type cage of glass fibre reinforced polyetheretherketone (PEEK), ball centred
<b>DT</b>	Two bearings matched in tandem	<b>P5</b>	Dimensional and running accuracy to ISO tolerance class 5
<b>E</b>	Optimized internal design	<b>P6</b>	Dimensional and running accuracy to ISO tolerance class 6
<b>F</b>	Machined window-type steel cage, ball centred	<b>W64</b>	Solid Oil filling
<b>GA</b>	Bearing for universal matching. Two bearings arranged back-to-back or face-to-face will have a light preload before mounting	<b>Y</b>	Pressed window-type brass cage, ball centred

Diagram 1

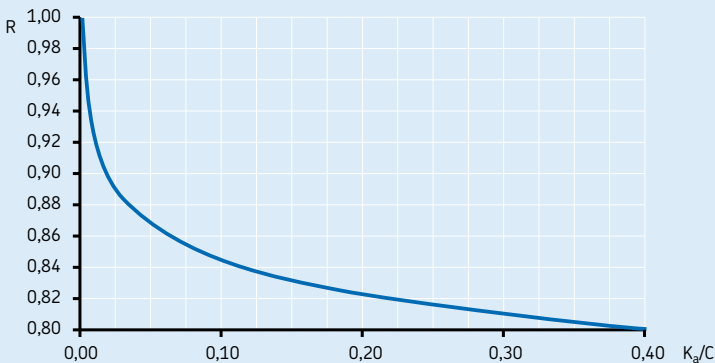

## Design of bearing arrangements

When designing bearing arrangements incorporating single row angular contact ball bearings, remember that these bearings must either be used with a second bearing or in sets (→ **fig. 4**).

When two single row angular contact ball bearings are used, they must be adjusted against each other until the requisite preload or clearance is obtained (→ section “Bearing preload”, starting on **page 206**).

Where bearings for universal matching are used and the bearings are mounted immediately adjacent to each other, there is no need for adjustment. The requisite preload or clearance is obtained by choosing bearings from an appropriate preload or clearance class and by applying suitable fits for the bearings on the shaft and in the housing.

It is important for proper bearing performance and for the operational reliability of the arrangement that the bearings are correctly adjusted, or that the correct choice of preload or clearance has been made. If the clearance of the bearing in operation is too large, the load carrying capacity of the bearings will not be fully utilized; on the other hand, excessive preload will produce more friction and higher operating

temperatures, leading to a reduction in bearing service life. It should also be remembered that with 72 B and 73 B series single row angular contact ball bearings ( $40^\circ$  contact angle), correct rolling conditions will only be achieved in the bearing when the load ratio  $F_a/F_r \geq 1$ .

Special attention should also be paid to back-to-back and face-to-face arrangements where the axial load acts predominantly in one direction. This creates an unfavourable rolling condition for the balls of the unloaded bearing and can lead to noise, discontinuity in the lubricant film and increased stressing of the cage. Under these conditions, zero operational clearance is recommended and should be attained, for example, by using springs. For additional information contact the SKF application engineering service.

Fig. 4

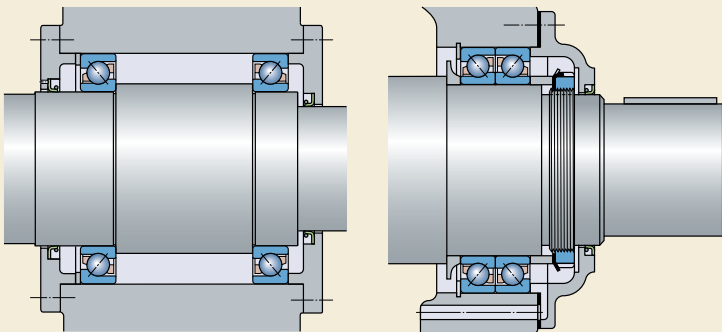



# Single row angular contact ball bearings

## d 10 – 25 mm

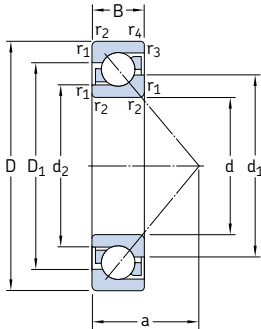

Principal dimensions			Basic load ratings		Fatigue load limit $P_u$	Speed ratings		Mass	Designations <sup>1)</sup>	
d	D	B	C	$C_0$		Refer- ence speed	Limiting speed		Universally matchable bearing	Basic design bearing
mm			kN		kN	r/min		kg	–	
<b>10</b>	30	9	7,02	3,35	0,14	30 000	30 000	0,030	<b>7200 BECBP</b>	<b>7200 BEP</b>
<b>12</b>	32 37	10 12	7,61 10,6	3,8 5	0,16 0,208	26 000 24 000	26 000 24 000	0,036 0,063	<b>7201 BECBP</b> –	<b>7201 BEP</b> <b>7301 BEP</b>
<b>15</b>	35 35 42	11 11 13	9,5 8,84 13	5,1 4,8 6,7	0,216 0,204 0,28	26 000 24 000 20 000	26 000 24 000 20 000	0,045 0,045 0,081	<b>* 7202 BECBP</b> – <b>7302 BECBP</b>	– <b>7202 BEP</b> <b>7302 BEP</b>
<b>17</b>	40 40 40 40 47	12 12 12 12 14	11 10,4 11,1 11 15,9	5,85 5,5 6,1 5,85 8,3	0,25 0,236 0,26 0,25 0,355	22 000 20 000 20 000 22 000 19 000	22 000 20 000 20 000 22 000 19 000	0,064 0,064 0,064 0,070 0,11	<b>* 7203 BECBP</b> – – <b>* 7203 BECBM</b> <b>7303 BECBP</b>	– <b>7203 BEP</b> <b>7203 BEY</b> – <b>7303 BEP</b>
<b>20</b>	47 47 47 47	14 14 14 14	14,3 13,3 14 13,3	8,15 7,65 8,3 7,65	0,345 0,325 0,355 0,325	19 000 18 000 18 000 18 000	19 000 18 000 18 000 19 000	0,11 0,11 0,11 0,11	<b>* 7204 BECBP</b> – <b>7204 BECBY</b> <b>7204 BECBM</b>	– <b>7204 BEP</b> – –
	52 52 52 52	15 15 15 15	19 17,4 19 19	10 9,5 10,4 10	0,425 0,4 0,44 0,425	18 000 16 000 16 000 18 000	18 000 16 000 16 000 18 000	0,14 0,14 0,15 0,15	<b>* 7304 BECBP</b> – <b>7304 BECBY</b> <b>* 7304 BECBM</b>	– <b>7304 BEP</b> <b>7304 BEY</b> –
<b>25</b>	52 52 52 52	15 15 15 15	15,6 14,8 15,6 15,6	10 9,3 10,2 10	0,43 0,4 0,43 0,43	17 000 15 000 15 000 17 000	17 000 15 000 15 000 17 000	0,13 0,13 0,13 0,14	<b>* 7205 BECBP</b> – <b>7205 BECBY</b> <b>* 7205 BECBM</b>	– <b>7205 BEP</b> <b>7205 BEY</b> –
	62 62 62 62	17 17 17 17	26,5 24,2 26 26,5	15,3 14 15,6 15,3	0,655 0,6 0,655 0,655	15 000 14 000 14 000 15 000	15 000 14 000 14 000 15 000	0,23 0,23 0,24 0,24	<b>* 7305 BECBP</b> – <b>7305 BECBY</b> <b>* 7305 BECBM</b>	– <b>7305 BEP</b> <b>7305 BEY</b> –

\* SKF Explorer bearing

<sup>1)</sup> For available final variants → **matrix 1** on page 419

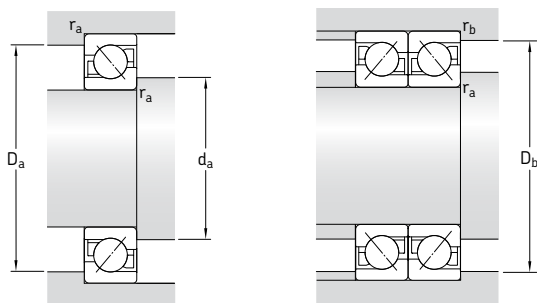

### Dimensions

### Abutment and fillet dimensions

d	d <sub>1</sub> -	d <sub>2</sub> -	D <sub>1</sub> -	r <sub>1,2</sub> min	r <sub>3,4</sub> min	a	d <sub>a</sub> min	D <sub>a</sub> max	D <sub>b</sub> max	r <sub>a</sub> max	r <sub>b</sub> max
mm	mm										
<b>10</b>	18,3	14,6	22,9	0,6	0,3	13	14,2	25,8	27,6	0,6	0,3
<b>12</b>	20,2 21,8	16,6 17	25 28,3	0,6 1	0,3 0,6	14,4 16,3	16,2 17,6	27,8 31,4	29,6 32,8	0,6 1	0,3 0,6
<b>15</b>	22,7 22,7 26	19 19 20,7	27,8 27,8 32,6	0,6 0,6 1	0,3 0,3 0,6	16 16 18,6	19,2 19,2 20,6	30,8 30,8 36,4	32,6 32,6 37,8	0,6 0,6 1	0,3 0,3 0,6
<b>17</b>	26,3 26,3 26,3 26,3 28,7	21,7 21,7 21,7 21,7 22,8	31,2 31,2 31,2 31,2 36,2	0,6 0,6 0,6 0,6 1	0,6 0,6 0,6 0,6 0,6	18 18 18 18 20,4	21,2 21,2 21,2 21,2 22,6	35,8 35,8 35,8 35,8 41,4	35,8 35,8 35,8 35,8 42,8	0,6 0,6 0,6 0,6 1	0,6 0,6 0,6 0,6 0,6
<b>20</b>	30,8 30,8 30,8 30,8	25,9 25,9 25,9 25,9	36,5 36,5 36,5 36,5	1 1 1 1	0,6 0,6 0,6 0,6	21 21 21 21	25,6 25,6 25,6 25,6	41,4 41,4 41,4 41,4	42,8 42,8 42,8 42,8	1 1 1 1	0,6 0,6 0,6 0,6
	33,3 33,3 33,3 33,3	26,8 26,8 26,8 26,8	40,4 40,4 40,4 40,4	1,1 1,1 1,1 1,1	0,6 0,6 0,6 0,6	22,8 22,8 22,8 22,8	27 27 27 27	45 45 45 45	47,8 47,8 47,8 47,8	1 1 1 1	0,6 0,6 0,6 0,6
<b>25</b>	36,1 36,1 36,1 36,1	30,9 30,9 30,9 30,9	41,5 41,5 41,5 41,5	1 1 1 1	0,6 0,6 0,6 0,6	23,7 23,7 23,7 23,7	30,6 30,6 30,6 30,6	46,4 46,4 46,4 46,4	47,8 47,8 47,8 47,8	1 1 1 1	0,6 0,6 0,6 0,6
	39,8 39,8 39,8 39,8	32,4 32,4 32,4 32,4	48,1 48,1 48,1 48,1	1,1 1,1 1,1 1,1	0,6 0,6 0,6 0,6	26,8 26,8 26,8 26,8	32 32 32 32	55 55 55 55	57,8 57,8 57,8 57,8	1 1 1 1	0,6 0,6 0,6 0,6

# Single row angular contact ball bearings

## d 30 – 45 mm

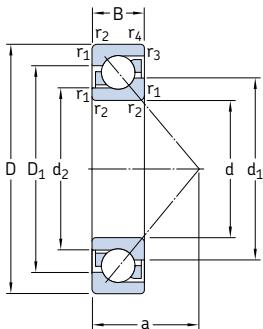

Principal dimensions			Basic load ratings		Fatigue load limit $P_u$	Speed ratings		Mass	Designations <sup>1)</sup>		
d	D	B	C	$C_0$		Refer- ence speed	Limiting speed		Universally matchable bearing	Basic design bearing	
mm			kN		kN	r/min		kg	–		
30	62	16	24	15,6	0,655	14 000	14 000	0,19	* 7206 BECBP	–	
	62	16	22,5	14,3	0,61	13 000	13 000	0,19	–	7206 BEP	
	62	16	23,8	15,6	0,655	13 000	13 000	0,21	* 7206 BECBy	7206 BEY	
	62	16	24	15,6	0,655	14 000	14 000	0,21	* 7206 BECBM	–	
	72	19	35,5	21,2	0,9	13 000	13 000	0,33	* 7306 BECBP	–	
	72	19	32,5	19,3	0,815	12 000	12 000	0,33	–	7306 BEP	
	72	19	34,5	21,2	0,9	12 000	12 000	0,37	* 7306 BECBy	7306 BEY	
	72	19	35,5	21,2	0,9	13 000	13 000	0,37	* 7306 BECBM	–	
	35	72	17	31	20,8	0,88	12 000	12 000	0,28	* 7207 BECBP	–
		72	17	29,1	19	0,815	11 000	11 000	0,28	–	7207 BEP
		72	17	30,7	20,8	0,88	11 000	11 000	0,30	* 7207 BECBy	7207 BEY
		72	17	31	20,8	0,88	12 000	12 000	0,30	* 7207 BECBM	–
80		21	41,5	26,5	1,14	11 000	11 000	0,45	* 7307 BECBP	–	
80		21	39	24,5	1,04	10 000	10 000	0,45	–	7307 BEP	
80		21	39	24,5	1,04	10 000	10 000	0,49	* 7307 BECBy	7307 BEY	
80		21	41,5	26,5	1,14	11 000	11 000	0,49	* 7307 BECBM	–	
40	80	18	36,5	26	1,1	11 000	11 000	0,37	* 7208 BECBP	–	
	80	18	34,5	24	1,02	10 000	10 000	0,37	–	7208 BEP	
	80	18	36,4	26	1,1	10 000	10 000	0,38	* 7208 BECBy	7208 BEY	
	80	18	36,5	26	1,1	11 000	11 000	0,39	* 7208 BECBM	–	
	80	18	34,5	24	1,02	10 000	10 000	0,39	–	7208 BEM	
	90	23	50	32,5	1,37	10 000	10 000	0,61	* 7308 BECBP	–	
	90	23	46,2	30,5	1,13	9 000	9 000	0,61	–	7308 BEP	
	90	23	49,4	33,5	1,4	9 000	9 000	0,64	* 7308 BECBy	7308 BEY	
	90	23	50	32,5	1,37	10 000	10 000	0,68	* 7308 BECBM	–	
	45	85	19	38	28,5	1,22	10 000	10 000	0,42	* 7209 BECBP	–
		85	19	35,8	26	1,12	9 000	9 000	0,42	–	7209 BEP
		85	19	37,7	28	1,2	9 000	9 000	0,43	* 7209 BECBy	7209 BEY
85		19	38	28,5	1,22	10 000	10 000	0,44	* 7209 BECBM	–	
100		25	61	40,5	1,73	9 000	9 000	0,82	* 7309 BECBP	–	
100		25	55,9	37,5	1,73	8 000	8 000	0,82	–	7309 BEP	
100		25	60,5	41,5	1,73	8 000	8 000	0,86	* 7309 BECBy	7309 BEY	
100		25	61	40,5	1,73	9 000	9 000	0,90	* 7309 BECBM	–	

\* SKF Explorer bearing

<sup>1)</sup> For available final variants → matrix 1 on page 419

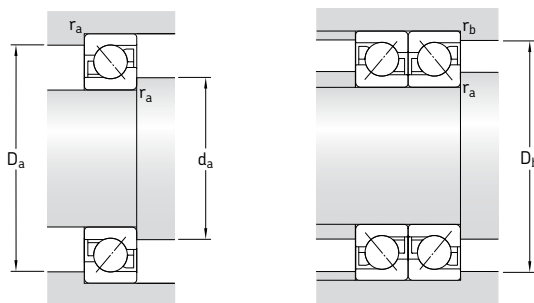

### Dimensions

### Abutment and fillet dimensions

d	d <sub>1</sub> ~	d <sub>2</sub> ~	D <sub>1</sub> ~	r <sub>1,2</sub> min	r <sub>3,4</sub> min	a	d <sub>a</sub> min	D <sub>a</sub> max	D <sub>b</sub> max	r <sub>a</sub> max	r <sub>b</sub> max	
mm	mm											
30	42,7	36,1	50,1	1	0,6	27,3	35,6	56,4	57,8	1	0,6	
	42,7	36,1	50,1	1	0,6	27,3	35,6	56,4	57,8	1	0,6	
	42,7	36,1	50,1	1	0,6	27,3	35,6	56,4	57,8	1	0,6	
	42,7	36,1	50,1	1	0,6	27,3	35,6	56,4	57,8	1	0,6	
	46,6	37,9	56,5	1,1	0,6	31	37	65	67,8	1	0,6	
	46,6	37,9	56,5	1,1	0,6	31	37	65	67,8	1	0,6	
	46,6	37,9	56,5	1,1	0,6	31	37	65	67,8	1	0,6	
	46,6	37,9	56,5	1,1	0,6	31	37	65	67,8	1	0,6	
	35	49,7	42	58,3	1,1	0,6	31	42	65	67,8	1	0,6
		49,7	42	58,3	1,1	0,6	31	42	65	67,8	1	0,6
		49,7	42	58,3	1,1	0,6	31	42	65	67,8	1	0,6
		49,7	42	58,3	1,1	0,6	31	42	65	67,8	1	0,6
52,8		43,6	63,3	1,5	1	35	44	71	74,4	1,5	1	
52,8		43,6	63,3	1,5	1	35	44	71	74,4	1,5	1	
52,8		43,6	63,3	1,5	1	35	44	71	74,4	1,5	1	
52,8		43,6	63,3	1,5	1	35	44	71	74,4	1,5	1	
40		56,3	48,1	65,6	1,1	0,6	34	47	73	75,8	1	0,6
		56,3	48,1	65,6	1,1	0,6	34	47	73	75,8	1	0,6
		56,3	48,1	65,6	1,1	0,6	34	47	73	75,8	1	0,6
		56,3	48,1	65,6	1,1	0,6	34	47	73	75,8	1	0,6
	56,3	48,1	65,6	1,1	0,6	34	47	73	75,8	1	0,6	
	59,7	49,6	71,6	1,5	1	39	49	81	84,4	1,5	1	
	59,7	49,6	71,6	1,5	1	39	49	81	84,4	1,5	1	
	59,7	49,6	71,6	1,5	1	39	49	81	84,4	1,5	1	
	59,7	49,6	71,6	1,5	1	39	49	81	84,4	1,5	1	
	45	60,9	52,7	70,2	1,1	0,6	37	52	78	80,8	1	0,6
		60,9	52,7	70,2	1,1	0,6	37	52	78	80,8	1	0,6
		60,9	52,7	70,2	1,1	0,6	37	52	78	80,8	1	0,6
60,9		52,7	70,2	1,1	0,6	37	52	78	80,8	1	0,6	
66,5		55,3	79,8	1,5	1	43	54	91	94,4	1,5	1	
66,5		55,3	79,8	1,5	1	43	54	91	94,4	1,5	1	
66,5		55,3	79,8	1,5	1	43	54	91	94,4	1,5	1	
66,5		55,3	79,8	1,5	1	43	54	91	94,4	1,5	1	

Single row angular contact ball bearings  
d 50 – 65 mm

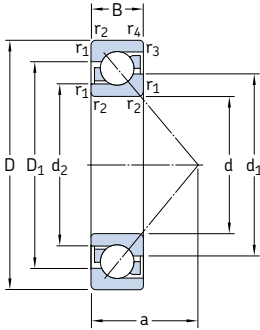

Principal dimensions			Basic load ratings		Fatigue load limit $P_u$	Speed ratings		Mass	Designations <sup>1)</sup>		
d	D	B	C	$C_0$		Reference speed	Limiting speed		Universally matchable bearing	Basic design bearing	
mm			kN		kN	r/min		kg	–		
50	90	20	40	31	1,32	9 000	9 000	0,47	* 7210 BECBP	–	
	90	20	37,7	28,5	1,22	8 500	8 500	0,47	–	7210 BEP	
	90	20	39	30,5	1,29	8 500	8 500	0,47	7210 BECBy	7210 BEY	
	90	20	40	31	1,32	9 000	9 000	0,51	* 7210 BECBM	–	
	110	27	75	51	2,16	8 000	8 000	1,04	* 7310 BECBP	–	
	110	27	68,9	47,5	2	7 500	7 500	1,04	–	7310 BEP	
	110	27	74,1	51	2,2	7 500	7 500	1,13	7310 BECBy	7310 BEY	
	110	27	75	51	2,16	8 000	8 000	1,16	* 7310 BECBM	–	
	55	100	21	49	40	1,66	8 000	8 000	0,62	* 7211 BECBP	–
		100	21	46,2	36	1,53	7 500	7 500	0,62	–	7211 BEP
		100	21	48,8	38	1,63	7 500	7 500	0,62	7211 BECBy	7211 BEY
		100	21	49	40	1,66	8 000	8 000	0,66	* 7211 BECBM	–
120		29	85	60	2,55	7 000	7 000	1,34	* 7311 BECBP	–	
120		29	79,3	55	2,32	6 700	6 700	1,34	–	7311 BEP	
120		29	85,2	60	2,55	6 700	6 700	1,48	7311 BECBy	7311 BEY	
120		29	85	60	2,55	7 000	7 000	1,49	* 7311 BECBM	–	
60	110	22	61	50	2,12	7 500	7 500	0,78	* 7212 BECBP	–	
	110	22	57,2	45,5	1,93	7 000	7 000	0,78	–	7212 BEP	
	110	22	57,2	45,5	1,93	7 000	7 000	0,83	7212 BECBy	7212 BEY	
	110	22	61	50	2,12	7 500	7 500	0,85	* 7212 BECBM	–	
	130	31	104	76,5	3,2	6 700	6 700	1,71	* 7312 BECBP	–	
	130	31	95,6	69,5	3	6 000	6 000	1,71	–	7312 BEP	
	130	31	95,6	69,5	3	6 000	6 000	1,75	7312 BECBy	7312 BEY	
	130	31	104	76,5	3,2	6 700	6 700	1,88	* 7312 BECBM	–	
	130	31	95,6	69,5	3	6 000	6 300	1,88	–	7312 BEM	
	65	120	23	66,3	54	2,28	6 300	6 300	1,00	7213 BECBP	7213 BEP
		120	23	66,3	54	2,28	6 300	6 300	1,00	7213 BECBy	7213 BEY
		120	23	66,3	54	2,28	6 300	6 700	1,10	7213 BECBM	–
140		33	116	86,5	3,65	6 300	6 300	2,10	* 7313 BECBP	–	
140		33	108	80	3,35	5 600	5 600	2,15	7313 BECBy	7313 BEP	
140		33	116	86,5	3,65	6 300	6 300	2,31	* 7313 BECBM	–	

\* SKF Explorer bearing

<sup>1)</sup> For available final variants → matrix 1 on page 419

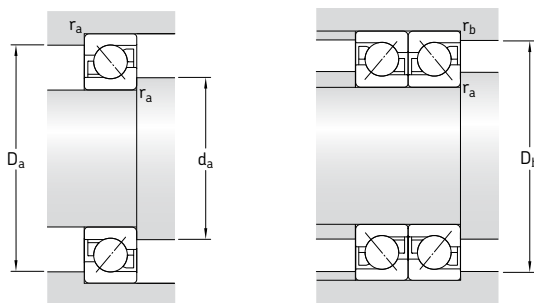
**Dimensions**
**Abutment and fillet dimensions**

d	d <sub>1</sub> ~	d <sub>2</sub> ~	D <sub>1</sub> ~	r <sub>1,2</sub> min	r <sub>3,4</sub> min	a	d <sub>a</sub> min	D <sub>a</sub> max	D <sub>b</sub> max	r <sub>a</sub> max	r <sub>b</sub> max	
mm	mm											
<b>50</b>	65,8	57,7	75,2	1,1	0,6	39	57	83	85,8	1	0,6	
	65,8	57,7	75,2	1,1	0,6	39	57	83	85,8	1	0,6	
	65,8	57,7	75,2	1,1	0,6	39	57	83	85,8	1	0,6	
	65,8	57,7	75,2	1,1	0,6	39	57	83	85,8	1	0,6	
	73,8	61,1	88,8	2	1	47	61	99	104	2	1	
	73,8	61,1	88,8	2	1	47	61	99	104	2	1	
	73,8	61,1	88,8	2	1	47	61	99	104	2	1	
	73,8	61,1	88,8	2	1	47	61	99	104	2	1	
	<b>55</b>	72,7	63,6	83,3	1,5	1	43	64	91	94	1,5	1
		72,7	63,6	83,3	1,5	1	43	64	91	94	1,5	1
72,7		63,6	83,3	1,5	1	43	64	91	94	1,5	1	
72,7		63,6	83,3	1,5	1	43	64	91	94	1,5	1	
80,3		66,7	96,6	2	1	51	66	109	114	2	1	
80,3		66,7	96,6	2	1	51	66	109	114	2	1	
80,3		66,7	96,6	2	1	51	66	109	114	2	1	
80,3		66,7	96,6	2	1	51	66	109	114	2	1	
<b>60</b>		79,6	69,3	91,6	1,5	1	47	69	101	104	1,5	1
		79,6	69,3	91,6	1,5	1	47	69	101	104	1,5	1
	79,6	69,3	91,6	1,5	1	47	69	101	104	1,5	1	
	79,6	69,3	91,6	1,5	1	47	69	101	104	1,5	1	
	87,3	72,6	104,8	2,1	1,1	55	72	118	123	2	1	
	87,3	72,6	104,8	2,1	1,1	55	72	118	123	2	1	
	87,3	72,6	104,8	2,1	1,1	55	72	118	123	2	1	
	87,3	72,6	104,8	2,1	1,1	55	72	118	123	2	1	
	87,3	72,6	104,8	2,1	1,1	55	72	118	123	2	1	
	<b>65</b>	86,4	75,5	100	1,5	1	50	74	111	114	1,5	1
86,4		75,5	100	1,5	1	50	74	111	114	1,5	1	
86,4		75,5	100	1,5	1	50	74	111	114	1,5	1	
94,2		78,5	112,9	2,1	1,1	60	77	128	133	2	1	
94,2		78,5	112,9	2,1	1,1	60	77	128	133	2	1	
94,2		78,5	112,9	2,1	1,1	60	77	128	133	2	1	

# Single row angular contact ball bearings d 70 – 85 mm

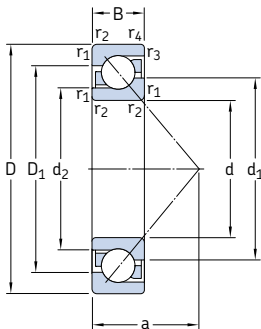

Principal dimensions			Basic load ratings		Fatigue load limit $P_u$	Speed ratings		Mass	Designations <sup>1)</sup>	
d	D	B	C	$C_0$		Refer- ence speed	Limiting speed		Universally matchable bearing	Basic design bearing
mm			kN		kN	r/min		kg	–	
<b>70</b>	125	24	75	64	2,7	6 300	6 300	1,10	* 7214 BECBP	–
	125	24	71,5	60	2,5	6 000	6 000	1,10	7214 BECBY	7214 BEP
	125	24	72	60	2,55	6 000	6 300	1,18	* 7214 BECBM	–
	150	35	127	98	3,9	5 600	5 600	2,55	* 7314 BECBP	–
	150	35	119	90	3,65	5 300	5 300	2,67	7314 BECBY	7314 BEP
	150	35	127	98	3,9	5 600	5 600	2,83	* 7314 BECBM	–
<b>75</b>	130	25	72,8	64	2,65	5 600	5 600	1,18	7215 BECBP	7215 BEP
	130	25	72,8	64	2,65	5 600	5 600	1,26	7215 BECBY	–
	130	25	70,2	60	2,5	5 600	6 000	1,29	7215 BECBM	–
	160	37	132	104	4,15	5 300	5 300	3,06	* 7315 BECBP	–
	160	37	125	98	3,8	5 000	5 000	3,06	–	7315 BEP
	160	37	133	106	4,15	5 000	5 000	3,20	7315 BECBY	–
<b>80</b>	140	26	85	75	3,05	5 600	5 600	1,43	* 7216 BECBP	–
	140	26	83,2	73,5	3	5 300	5 300	1,58	7216 BECBY	–
	140	26	85	75	3,05	5 600	5 600	1,59	* 7216 BECBM	–
	170	39	143	118	4,5	5 000	5 000	3,64	* 7316 BECBP	–
	170	39	135	110	4,15	4 500	4 500	3,64	–	7316 BEP
	170	39	143	118	4,5	4 500	4 500	3,70	7316 BECBY	7316 BEY
<b>85</b>	150	28	95,6	83	3,25	5 000	5 000	1,83	* 7217 BECBP	–
	150	28	95,6	83	3,25	5 000	5 000	1,83	7217 BECBY	7217 BEP
	150	28	95,6	83	3,25	5 000	5 300	1,99	7217 BECBM	–
	180	41	156	132	4,9	4 800	4 800	4,26	* 7317 BECBP	–
	180	41	146	112	4,5	4 300	4 300	4,26	–	7317 BEP
	180	41	153	132	4,9	4 300	4 300	4,59	7317 BECBY	–
	180	41	156	132	4,9	4 800	4 800	4,74	* 7317 BECBM	–
	180	41	146	112	4,5	4 300	4 500	4,74	–	7317 BEP

\* SKF Explorer bearing

<sup>1)</sup> For available final variants → matrix 1 on page 419

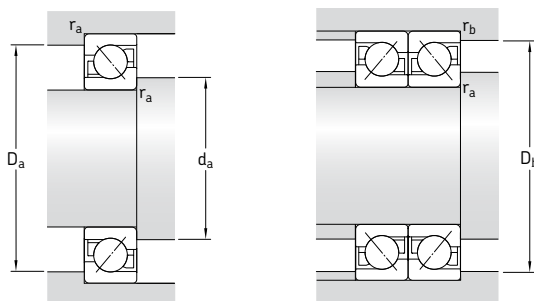

### Dimensions

### Abutment and fillet dimensions

d	d <sub>1</sub> ~	d <sub>2</sub> ~	D <sub>1</sub> ~	r <sub>1,2</sub> min	r <sub>3,4</sub> min	a	d <sub>a</sub> min	D <sub>a</sub> max	D <sub>b</sub> max	r <sub>a</sub> max	r <sub>b</sub> max
mm							mm				
<b>70</b>	91,5	80,3	104,8	1,5	1	53	79	116	119	1,5	1
	91,5	80,3	104,8	1,5	1	53	79	116	119	1,5	1
	91,5	80,3	104,8	1,5	1	53	79	116	119	1,5	1
	101,1	84,4	121	2,1	1,1	64	82	138	143	2	1
	101,1	84,4	121	2,1	1,1	64	82	138	143	2	1
	101,1	84,4	121	2,1	1,1	64	82	138	143	2	1
<b>75</b>	96,3	85,3	110,1	1,5	1	56	84	121	124	1,5	1
	96,3	85,3	110,1	1,5	1	56	84	121	124	1,5	1
	96,3	85,3	110,1	1,5	1	56	84	121	124	1,5	1
	108,3	91,1	128,7	2,1	1,1	68	87	148	153	2	1
	108,3	91,1	128,7	2,1	1,1	68	87	148	153	2	1
	108,3	91,1	128,7	2,1	1,1	68	87	148	153	2	1
<b>80</b>	103,6	91,4	117,9	2	1	59	91	129	134	2	1
	103,6	91,4	117,9	2	1	59	91	129	134	2	1
	103,6	91,4	117,9	2	1	59	91	129	134	2	1
	115,2	97,1	136,8	2,1	1,1	72	92	158	163	2	1
	115,2	97,1	136,8	2,1	1,1	72	92	158	163	2	1
	115,2	97,1	136,8	2,1	1,1	72	92	158	163	2	1
<b>85</b>	110,1	97	126,7	2	1	63	96	139	144	2	1
	110,1	97	126,7	2	1	63	96	139	144	2	1
	110,1	97	126,7	2	1	63	96	139	144	2	1
	122,3	103	145	3	1,1	76	99	166	173	2,5	1
	122,3	103	145	3	1,1	76	99	166	173	2,5	1
	122,3	103	145	3	1,1	76	99	166	173	2,5	1

# Single row angular contact ball bearings

## d 90 – 105 mm

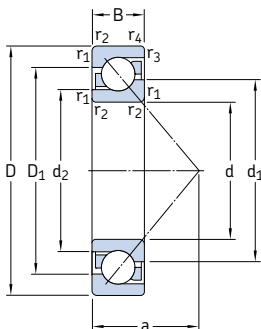

Principal dimensions			Basic load ratings		Fatigue load limit $P_u$	Speed ratings		Mass	Designations <sup>1)</sup>		
d	D	B	C	$C_0$		Refer- ence speed	Limiting speed		Universally matchable bearing	Basic design bearing	
mm			kN		kN	r/min		kg	–		
90	160	30	116	104	4	4 800	4 800	2,12	* 7218 BECBP	–	
	160	30	108	96,5	3,65	4 500	4 500	2,34	7218 BECBEY	7218 BEP	
	160	30	108	96,5	3,65	4 500	4 800	2,41	7218 BECBM	–	
	190	43	166	146	5,3	4 500	4 500	4,98	* 7318 BECBP	–	
	190	43	156	134	4,8	4 000	4 000	4,98	–	7318 BEP	
	190	43	165	146	5,2	4 000	4 000	5,22	7318 BECBEY	–	
	190	43	166	146	5,3	4 500	4 500	5,53	* 7318 BECBM	–	
	190	43	156	134	4,8	4 000	4 300	5,53	–	7318 BEM	
	95	170	32	129	118	4,4	4 800	4 800	2,68	* 7219 BECBP	–
		170	32	124	108	4	4 300	4 300	2,68	–	7219 BEP
170		32	124	108	4	4 300	4 300	2,82	7219 BECBEY	–	
170		32	129	118	4,4	4 800	4 800	2,95	* 7219 BECBM	–	
200		45	180	163	5,7	4 300	4 300	5,77	* 7319 BECBP	–	
200		45	168	150	5,2	3 800	3 800	5,77	–	7319 BEP	
200		45	178	163	5,6	3 800	3 800	6,17	7319 BECBEY	–	
200		45	180	163	5,7	4 300	4 300	6,41	* 7319 BECBM	–	
200		45	168	150	5,2	3 800	4 000	6,41	–	7319 BEM	
100		180	34	143	134	4,75	4 500	4 500	3,29	* 7220 BECBP	–
	180	34	135	122	4,4	4 000	4 000	3,29	–	7220 BEP	
	180	34	135	122	4,4	4 000	4 000	3,38	7220 BECBEY	7220 BEY	
	180	34	135	122	4,4	4 000	4 300	3,61	7220 BECBM	–	
	215	47	216	208	6,95	4 000	4 000	7,17	* 7320 BECBP	–	
	215	47	203	190	6,4	3 600	3 600	7,17	–	7320 BEP	
	215	47	203	190	6,4	3 600	3 600	7,15	7320 BECBEY	7320 BEY	
	215	47	216	208	6,95	4 000	4 000	8,00	* 7320 BECBM	–	
	215	47	203	190	6,4	3 600	3 800	8,00	–	7320 BEM	
	105	190	36	156	150	5,2	4 300	4 300	3,82	* 7221 BECBP	–
190		36	148	137	4,8	3 800	4 000	4,18	7221 BECBM	–	
225		49	228	228	7,5	3 800	3 800	8,46	* 7321 BECBP	–	
225		49	203	193	6,4	3 400	3 600	9,12	7321 BECBM	–	

\* SKF Explorer bearing

<sup>1)</sup> For available final variants → matrix 1 on page 419

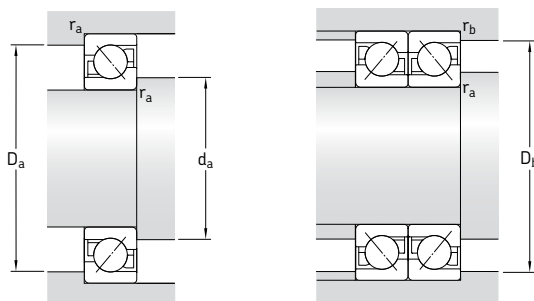

### Dimensions

### Abutment and fillet dimensions

d	d <sub>1</sub> ~	d <sub>2</sub> ~	D <sub>1</sub> ~	r <sub>1,2</sub> min	r <sub>3,4</sub> min	a	d <sub>a</sub> min	D <sub>a</sub> max	D <sub>b</sub> max	r <sub>a</sub> max	r <sub>b</sub> max
mm	mm										
<b>90</b>	117,1	103	134,8	2	1	67	101	149	154	2	1
	117,1	103	134,8	2	1	67	101	149	154	2	1
	117,1	103	134,8	2	1	67	101	149	154	2	1
	129,2	109	153,1	3	1,1	80	104	176	183	2,5	1
	129,2	109	153,1	3	1,1	80	104	176	183	2,5	1
	129,2	109	153,1	3	1,1	80	104	176	183	2,5	1
	129,2	109	153,1	3	1,1	80	104	176	183	2,5	1
	129,2	109	153,1	3	1,1	80	104	176	183	2,5	1
	129,2	109	153,1	3	1,1	80	104	176	183	2,5	1
	129,2	109	153,1	3	1,1	80	104	176	183	2,5	1
<b>95</b>	124,3	109,1	142,5	2,1	1,1	72	107	158	163	2	1
	124,3	109,1	142,5	2,1	1,1	72	107	158	163	2	1
	124,3	109,1	142,5	2,1	1,1	72	107	158	163	2	1
	124,3	109,1	142,5	2,1	1,1	72	107	158	163	2	1
	136,2	114,9	161,3	3	1,1	84	109	186	193	2,5	1
	136,2	114,9	161,3	3	1,1	84	109	186	193	2,5	1
	136,2	114,9	161,3	3	1,1	84	109	186	193	2,5	1
	136,2	114,9	161,3	3	1,1	84	109	186	193	2,5	1
	136,2	114,9	161,3	3	1,1	84	109	186	193	2,5	1
	136,2	114,9	161,3	3	1,1	84	109	186	193	2,5	1
<b>100</b>	131	115,2	150,9	2,1	1,1	76	112	168	173	2	1
	131	115,2	150,9	2,1	1,1	76	112	168	173	2	1
	131	115,2	150,9	2,1	1,1	76	112	168	173	2	1
	131	115,2	150,9	2,1	1,1	76	112	168	173	2	1
	144,5	120,5	173,4	3	1,1	90	114	201	208	2,5	1
	144,5	120,5	173,4	3	1,1	90	114	201	208	2,5	1
	144,5	120,5	173,4	3	1,1	90	114	201	208	2,5	1
	144,5	120,5	173,4	3	1,1	90	114	201	208	2,5	1
	144,5	120,5	173,4	3	1,1	90	114	201	208	2,5	1
	144,5	120,5	173,4	3	1,1	90	114	201	208	2,5	1
<b>105</b>	138	121,2	159,1	2,1	1,1	80	117	178	183	2	1
	138	121,2	159,1	2,1	1,1	80	117	178	183	2	1
	151,7	127,9	181,4	3	1,1	94	119	211	218	2,5	1
	151,7	127,9	181,4	3	1,1	94	119	211	218	2,5	1

Single row angular contact ball bearings  
d 110 – 240 mm

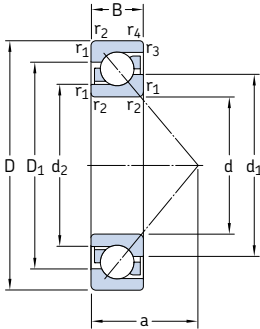

Principal dimensions			Basic load ratings		Fatigue load limit $P_u$	Speed ratings		Mass	Designations <sup>1)</sup>	
d	D	B	C	$C_0$		Refer- ence speed	Limiting speed		Universally matchable bearing	Basic design bearing
mm			kN		kN	r/min		kg	–	
<b>110</b>	200	38	170	166	4,7	4 000	4 000	4,60	* 7222 BECBP	–
	200	38	163	153	5,2	3 600	3 600	4,75	7222 BECBY	–
	200	38	153	143	4,9	3 600	3 800	4,95	7222 BECBM	7222 BEM
	240	50	240	245	7,8	3 600	3 600	9,69	* 7322 BECBP	–
	240	50	225	224	7,2	3 200	3 200	9,69	7322 BECBY	7322 BEY
	240	50	225	224	7,2	3 200	3 400	10,7	7322 BECBM	7322 BEM
<b>120</b>	215	40	165	163	5,3	3 400	3 600	5,89	7224 BCBCM	7224 BM
	260	55	238	250	7,65	3 000	3 200	13,8	7324 BCBCM	–
<b>130</b>	230	40	186	193	6,1	3 200	3 400	6,76	7226 BCBCM	7226 BM
	280	58	276	305	9	2 800	2 800	17,1	7326 BCBCM	7326 BM
<b>140</b>	250	42	199	212	6,4	2 800	3 000	8,63	7228 BCBCM	7228 BM
	300	62	302	345	9,8	2 600	2 600	21,3	7328 BCBCM	–
<b>150</b>	270	45	216	240	6,95	2 600	2 800	10,8	7230 BCBCM	–
	320	65	332	390	10,8	2 400	2 400	25,0	7330 BCBCM	–
<b>160</b>	290	48	255	300	8,5	2 400	2 600	13,6	7232 BCBCM	–
<b>170</b>	310	52	281	345	9,5	2 400	2 400	16,7	7234 BCBCM	–
	360	72	390	490	12,7	2 000	2 200	34,6	7334 BCBCM	–
<b>180</b>	320	52	291	375	10	2 200	2 400	17,6	7236 BCBCM	–
	380	75	410	540	13,7	2 000	2 000	40,0	7336 BCBCM	–
<b>190</b>	340	55	307	405	10,4	2 000	2 200	21,9	7238 BCBCM	–
	400	78	442	600	14,6	1 900	1 900	48,3	7338 BCBCM	–
<b>200</b>	360	58	325	430	11	1 800	2 000	25,0	7240 BCBCM	–
	420	80	462	655	15,6	1 800	1 800	52,8	7340 BCBCM	–
<b>220</b>	400	65	390	560	13,4	1 800	1 800	35,2	7244 BCBCM	–
<b>240</b>	440	72	364	540	12,5	1 600	1 700	49,0	7248 BCBCM	–

\* SKF Explorer bearing

<sup>1)</sup> For available final variants → matrix 1 on page 419

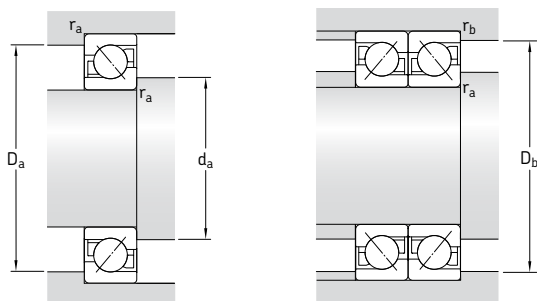

### Dimensions

### Abutment and fillet dimensions

d	d <sub>1</sub> ~	d <sub>2</sub> ~	D <sub>1</sub> ~	r <sub>1,2</sub> min	r <sub>3,4</sub> min	a	d <sub>a</sub> min	D <sub>a</sub> max	D <sub>b</sub> max	r <sub>a</sub> max	r <sub>b</sub> max
mm	mm										
<b>110</b>	144,9	127,1	167,4	2,1	1,1	84	122	188	193	2	1
	144,9	127,1	167,4	2,1	1,1	84	122	188	193	2	1
	144,9	127,1	167,4	2,1	1,1	84	122	188	193	2	1
	160,8	135	193,5	3	1,1	99	124	226	233	2,5	1
	160,8	135	193,5	3	1,1	99	124	226	233	2,5	1
160,8	135	193,5	3	1,1	99	124	226	233	2,5	1	
<b>120</b>	157	138,6	179,4	2,1	1,1	90	132	203	208	2	1
	178,4	153,9	211	3	1,5	107	134	246	253	2,5	1
<b>130</b>	169	149,6	192,6	3	1,1	96	144	216	222	2,5	1
	189,9	161,4	227,5	4	1,5	115	147	263	271	3	1,5
<b>140</b>	183,3	163,6	209,5	3	1,1	103	154	236	243	2,5	1
	203	172,2	243	4	1,5	123	157	283	291	3	1,5
<b>150</b>	197,2	175,6	226	3	1,1	111	164	256	263	2,5	1
	216,1	183,9	258,7	4	1,5	131	167	303	311	3	1,5
<b>160</b>	211	187,6	242,3	3	1,1	118	174	276	283	2,5	1
<b>170</b>	227,4	202	261	4	1,5	127	187	293	301	3	1,5
	243,8	207,9	292	4	2	147	187	343	351	3	1,5
<b>180</b>	234,9	209,6	268,8	4	1,5	131	197	303	311	3	1,5
	257,7	219,8	308	4	2	156	197	363	369	3	2
<b>190</b>	250,4	224,1	285,4	4	1,5	139	207	323	331	3	1,5
	271,6	231,8	324,3	5	2	164	210	380	389	4	2
<b>200</b>	263,3	235,1	300,8	4	1,5	146	217	343	351	3	1,5
	287	247	339,5	5	2	170	220	400	409	4	2
<b>220</b>	291,1	259,1	333,4	4	1,5	164	237	383	391	3	1,5
<b>240</b>	322	292	361	4	1,5	180	257	423	431	3	1,5



# Double row angular contact ball bearings

<b>Designs</b> .....	<b>434</b>
Basic design bearings .....	435
Sealed bearings .....	435
Bearings with a two-piece inner ring .....	436
<b>SKF Explorer class bearings</b> .....	<b>437</b>
<b>Bearing data – general</b> .....	<b>437</b>
Dimensions .....	437
Tolerances .....	437
Internal clearance .....	438
Misalignment .....	438
Influence of operating temperature on bearing material .....	438
Cages .....	438
Minimum load .....	439
Equivalent dynamic bearing load .....	440
Equivalent static bearing load .....	440
Supplementary designations .....	440
<b>Product tables</b> .....	<b>442</b>
Double row angular contact ball bearings .....	442
Sealed double row angular contact ball bearings .....	446

### Designs

SKF double row angular contact ball bearings correspond in design to two single row angular contact ball bearings but take up less axial space. They can accommodate radial loads as well as axial loads acting in both directions. They provide stiff bearing arrangements and are able to accommodate tilting moments.

The SKF standard range of double row angular contact ball bearings (→ **fig. 1**) includes

- basic design bearings (**a**)
- sealed bearings (**b**)
- bearings with a two-piece inner ring (**c**).

The standard range is shown in **matrix 1** on **page 441**.

This bearing range covers sizes from 10 to 110 mm bore diameter. For information about other double row angular contact ball bearings, please refer to the “SKF Interactive Engineering Catalogue” online at [www.skf.com](http://www.skf.com).

#### Bearings in the 52 A and 53 A series

Basic design bearings in the 32 A and 33 A series shown in the product table as well as the corresponding sealed bearings to 2Z and 2RS1 design are identical to the corresponding bearings in the 52 and 53 series for the North American market. They have the same performance characteristics and dimensional features (except for the width of size 5200). However, the sealed bearings are filled with a different grease. Bearings in the 52 and 53 series use a mineral oil based high-temperature grease with polyurea thickener. The operating temperature range of this grease is  $-30$  to  $+140$  °C. The base oil viscosity is  $115$  mm<sup>2</sup>/s at  $40$  °C and  $12$  mm<sup>2</sup>/s at  $100$  °C.

Fig. 1

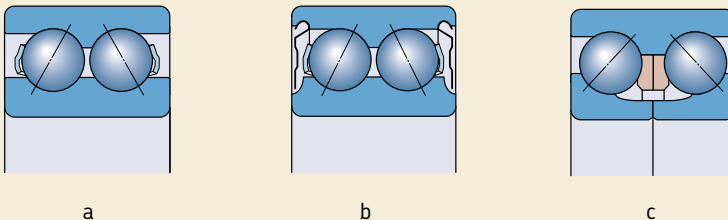

## Basic design bearings

SKF double row angular contact ball bearings in the 32 A and 33 A series have optimized internal geometry and do not have filling slots. The advantages are

- universal applicability
- high radial and axial load carrying capacity in both directions
- quiet operation.

The bearings have a 30° contact angle and the ball sets are in a back-to-back arrangement.

Standard design bearings that are also available with seals or shields may, for manufacturing reasons, have seal recesses on inner and outer rings (→ **fig. 2**).

## Sealed bearings

The most common basic design bearings can also be supplied with shields or seals (→ **matrix 1** on **page 441**). Bearings in the 32 A and 33 A series are filled with a high-quality NLGI class 3 grease with a lithium thickener and are marked with the designation suffix MT33. This grease has good corrosion inhibiting properties and has a temperature range of -30 to +120 °C<sup>1)</sup>. The base oil viscosity is 98 mm<sup>2</sup>/s at 40 °C and 9,4 mm<sup>2</sup>/s at 100 °C. Regarding the grease fill of bearings in the 52 A and 53 A series please refer to **page 434**.

Sealed bearings are lubricated for life and are maintenance-free. They should therefore not be washed or heated above 80 °C before mounting.

## Bearings with shields

Bearings with shields, designation suffix 2Z, are produced in two different designs (→ **fig. 3**). The sheet steel shields used in smaller bearings form a narrow gap with the land of the inner ring shoulder (**a**). Larger bearings as well as all SKF Explorer bearings have recesses in the inner ring side faces into which the shields extend (**b**).

Shielded bearings are primarily intended for applications where the inner ring rotates. If the outer ring rotates there is a risk that grease will be lost from the bearing once it reaches a certain speed.

Fig. 2



Fig. 3

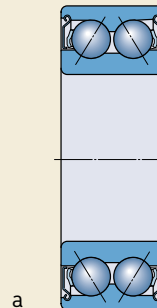

a



b

<sup>1)</sup> For safe operating temperature, → section "Temperature range – the SKF traffic light concept", starting on **page 232**

## Double row angular contact ball bearings

### Bearings with seals

Bearings with seals, designation suffix 2RS1, use a acrylonitrile-butadiene rubber, sheet steel reinforced seal that fits against a recess in the inner ring side face (→ **fig. 4**). The lip of the seal exerts a light pressure against the inner ring for a positive seal. The periphery of the seal engages in a recess in the outer ring to provide a good sealing. The permissible operating temperature range for these seals is  $-40$  to  $+100$  °C and up to  $+120$  °C for brief periods.

Grease may be lost from sealed bearings at the inner ring under extreme operating conditions, e.g. at high speeds or at high temperatures. For applications where this could be a disadvantage, special design steps should be taken to prevent this. For additional information please contact the SKF application engineering service.

### Bearings with a two-piece inner ring

In addition to the basic design bearings, double row angular contact ball bearings are also available with a two-piece inner ring (→ **fig. 5**). These bearings incorporate a large number of large balls and have a high load carrying capacity, especially in the axial direction.

### Bearings in the 33 D series

Bearings in the 33 D series (**a**) have a  $45^\circ$  contact angle, a special internal clearance and can support heavy axial loads in both directions. The bearings are separable, i.e. the outer ring with ball and cage assemblies can be mounted independently of the inner ring halves.

### Bearings in the 33 DNRCBM series

Bearings in the 33 DNRCBM series (**b**) have a  $40^\circ$  contact angle and a snap ring groove with snap ring in the outer ring, enabling simple and space-saving axial location in the housing. They have been designed specifically to operate under the conditions pertaining in centrifugal pumps, but can also be used in other applications. These bearings are non-separable.

Fig. 4



Fig. 5

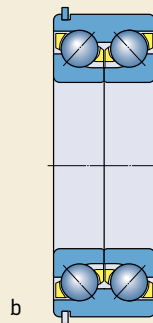

## SKF Explorer class bearings

High performance SKF Explorer angular contact ball bearings are shown with an asterisk in the product tables. SKF Explorer bearings retain the designation of the earlier standard bearings, e.g. 3208 ATN9. However, each bearing and its box are marked with the name "EXPLORER".

## Bearing data – general

### Dimensions

The boundary dimensions of SKF double row angular contact ball bearings are in accordance with ISO 15:1998, except for the width of bearing 3200 A.

The dimensions of the snap ring grooves and snap rings for bearings in the 33 DNRCBM series are listed in **table 1**. The dimensions of the snap ring grooves and snap rings conform to ISO 464:1995.

### Tolerances

SKF basic design double row angular contact ball bearings are produced to Normal tolerances as standard. SKF Explorer bearings as well as bearings in the 33 DNRCBM series are produced to tolerance class P6 specifications.

The values for tolerances correspond to ISO 492:2002 and can be found in **tables 3** and **4** on **pages 125** and **126**.

Table 1

Dimensions of snap ring grooves and snap rings

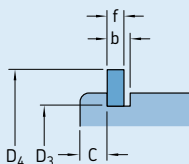

Bearing Designation	Dimensions					Snap ring Designation
	C	b	f	D <sub>3</sub>	D <sub>4</sub>	
–	mm					–
3308 DNRCBM	3,28	2,7	2,46	86,8	96,5	SP 90
3309 DNRCBM	3,28	2,7	2,46	96,8	106,5	SP 100
3310 DNRCBM	3,28	2,7	2,46	106,8	116,6	SP 110
3311 DNRCBM	4,06	3,4	2,82	115,2	129,7	SP 120
3313 DNRCBM	4,06	3,4	2,82	135,2	149,7	SP 140

## Double row angular contact ball bearings

### Internal clearance

SKF double row angular contact ball bearings in the 32 A and 33 A series are produced as standard with Normal axial internal clearance. They are also available with the greater C3 clearance (→ **matrix 1** on **page 441**). For bearings with smaller C2 clearance, please check availability before ordering.

Bearings in the 33 D and 33 DNRCBM series are produced exclusively with an axial internal clearance according to the values provided in **table 2**. They are valid for bearings before mounting under zero measuring loads.

### Misalignment

Misalignment of the outer ring with respect to the inner ring of double row angular contact ball bearings can only be accommodated by generating forces between the balls and the raceways. Any misalignment will lead to increased noise in operation and reduced bearing service life.

### Influence of operating temperature on bearing material

SKF angular contact ball bearings undergo a special heat treatment. When equipped with a steel or brass cage, they can operate at temperatures of up to +150 °C.

### Cages

Depending on the bearing series, size and design, SKF double row angular contact ball bearings are fitted as standard with two of each of the following cages (→ **fig. 6**)

- an injection moulded snap-type cage of glass fibre reinforced polyamide 6,6, ball centred, designation suffix TN9 (**a**)
- a pressed snap-type steel cage, ball centred, no designation suffix or suffix J1 (**b**)
- a pressed steel crown cage, ball centred, no designation suffix (**c**)
- a pronged machined brass cage, outer ring centred, designation suffix MA (**d**)

Table 2

Axial internal clearance of double row angular contact ball bearings

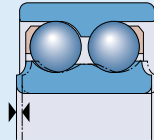

Bore diameter d over incl.		Axial internal clearance of bearings in series 32 A and 33 A								33 D		33 DNRCBM	
		C2		Normal		C3		min	max	min	max		
		min	max	min	max	min	max			min	max		
mm		µm								µm		µm	
–	<b>10</b>	1	11	5	21	12	28	–	–	–	–		
<b>10</b>	<b>18</b>	1	12	6	23	13	31	–	–	–	–		
<b>18</b>	<b>24</b>	2	14	7	25	16	34	–	–	–	–		
<b>24</b>	<b>30</b>	2	15	8	27	18	37	–	–	–	–		
<b>30</b>	<b>40</b>	2	16	9	29	21	40	33	54	10	30		
<b>40</b>	<b>50</b>	2	18	11	33	23	44	36	58	10	30		
<b>50</b>	<b>65</b>	3	22	13	36	26	48	40	63	18	38		
<b>65</b>	<b>80</b>	3	24	15	40	30	54	46	71	18	38		
<b>80</b>	<b>100</b>	3	26	18	46	35	63	55	83	–	–		
<b>100</b>	<b>110</b>	4	30	22	53	42	73	65	96	–	–		

- a machined window-type brass cage, ball centred, designation suffix M (e).

Several bearings are available as standard with a choice of cage design so that bearings with a cage appropriate to the operating conditions can be chosen (→ **matrix 1** on **page 441**).

**Note**

Bearings with polyamide 6,6 cages can be operated at temperatures up to +120 °C. The lubricants generally used for rolling bearings do not have a detrimental effect on cage properties, with the exception of a few synthetic oils and greases with a synthetic oil base, and lubricants containing a high proportion of EP additives when used at high temperatures.

For detailed information about the temperature resistance and the applicability of cages, please refer to the section “Cage materials”, starting on **page 140**.

**Minimum load**

In order to provide satisfactory operation, double row angular contact ball bearings, like all ball and roller bearings, must always be subjected to a given minimum load, particularly if they are to operate at high speeds or are subjected to high accelerations or rapid changes in the direction of load. Under such conditions, the inertia forces of the balls and cages, and the friction in the lubricant, can have a detrimental influence on the rolling conditions in the bearing arrangement

and may cause damaging sliding movements to occur between the balls and raceways.

The requisite minimum radial load to be applied to double row angular contact ball bearings can be estimated using

$$F_{rm} = k_r \left( \frac{v n}{1\ 000} \right)^{2/3} \left( \frac{d_m}{100} \right)^2$$

where

$F_{rm}$  = minimum radial load, kN

$k_r$  = minimum radial load factor

0,06 for bearings in the 32 A series

0,07 for bearings in the 33 A series

0,095 for bearings in the 33 D and

33 DNR series

$v$  = oil viscosity at operating temperature, mm<sup>2</sup>/s

$n$  = rotational speed, r/min

$d_m$  = bearing mean diameter  
= 0,5 (d + D), mm

When starting up at low temperatures or when the lubricant is highly viscous, even greater minimum loads may be required. The weight of the components supported by the bearing, together with external forces, generally exceed the requisite minimum load. If this is not the case, the double row angular contact ball bearing must be subjected to an additional radial load.

Fig. 6

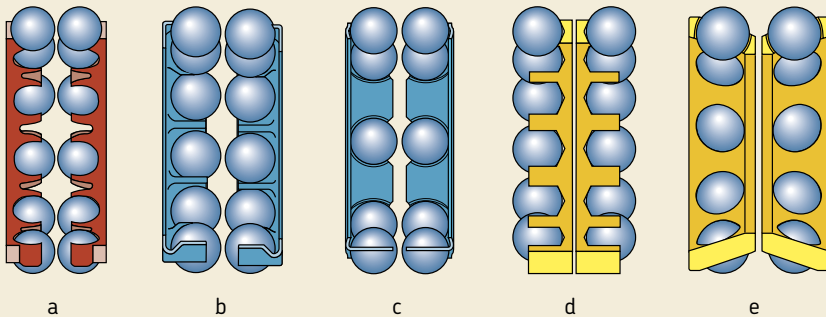

## Double row angular contact ball bearings

### Equivalent dynamic bearing load

$$P = F_r + Y_1 F_a \quad \text{when } F_a/F_r \leq e$$

$$P = X F_r + Y_2 F_a \quad \text{when } F_a/F_r > e$$

The values for the factors  $e$ ,  $X$ ,  $Y_1$  and  $Y_2$  depend on the bearing contact angle and are listed in **table 3**.

### Equivalent static bearing load

$$P_0 = F_r + Y_0 F_a$$

The value for the factor  $Y_0$  depends on the bearing contact angle and is provided in **table 3**.

### Supplementary designations

The designation suffixes used to identify certain features of SKF double row angular contact ball bearings are explained in the following.

- A** No filling slots
- CB** Controlled axial internal clearance
- C2** Axial internal clearance smaller than Normal
- C3** Axial internal clearance greater than Normal
- D** Two-piece inner ring
- J1** Pressed snap-type steel cage, ball centred
- M** Machined window-type brass cage, ball centred
- MA** Pronged machined brass cage, outer ring centred
- MT33** Grease with lithium thickener of consistency 3 to the NLGI Scale for a temperature range  $-30$  to  $+120$  °C (normal fill grade)
- N** Snap ring groove in the outer ring
- NR** Snap ring groove in the outer ring, with snap ring
- P5** Dimensional and running accuracy to ISO tolerance class 5
- P6** Dimensional and running accuracy to ISO tolerance class 6
- P62** P6 + C2
- P63** P6 + C3
- 2RS1** Sheet steel reinforced contact seal of acrylonitrile-butadiene rubber (NBR) on both sides of the bearing
- TN9** Injection moulded snap-type cage of glass fibre reinforced polyamide 6,6, ball centred
- W64** Solid Oil filling
- ZZ** Shield of pressed sheet steel on both sides of the bearing

Table 3

Calculation factors for double row angular contact ball bearings					
Bearing series	Calculation factors				
	e	X	Y <sub>1</sub>	Y <sub>2</sub>	Y <sub>0</sub>
32 A (52 A)	0,8	0,63	0,78	1,24	0,66
33 A (53 A)	0,8	0,63	0,78	1,24	0,66
33 D	1,34	0,54	0,47	0,81	0,44
33 DNRCBM	1,14	0,57	0,55	0,93	0,52

## SKF double row angular contact ball bearings – standard assortment

Bore diameter, mm	Basic design bearings				Bearings with shields				Bearings with seals				Bearings with a two-piece inner ring				Bearing size											
	32 A	32 A/C3	32 ATN9	32 ATN9/C3	33 A	33 A/C3	33 ATN9	33 ATN9/C3	32 A-ZZ/MT33	32 A-ZZ/C3MT33	32 A-ZZTN9/MT33	32 A-ZZTN9/C3MT33	33 A-ZZ/MT33	33 A-ZZ/C3MT33	33 A-ZZTN9/MT33	33 A-ZZTN9/C3MT33		32 A-2RS1/MT33	32 A-2RS1TN9/MT33	33 A-2RS1/MT33	33 A-2RS1TN9/MT33	33 DJ1	33 DTN9	33 DNA	33 DNRCBM			
10																											00	
12																												01
15																												02
17																												03
20																												04
25																												05
30																												06
35																												07
40																												08
45																												09
50																												10
55																												11
60																												12
65																												13
70																												14
75																												15
80																												16
85																												17
90																												18
95																												19
100																												20
110																												22

 SKF Explorer bearings  
 Other SKF standard bearings

**Bearings in the 52 A and 53 A series**

This matrix is also valid for bearings in the 52 A and 53 A series, which are identical to the corresponding bearings in the 32 A and 33 A series. However, sealed bearings in the 52 A and 53 A series are filled with a high-temperature grease (→ [page 434](#)). They do not carry any designation suffix for the grease.

**Bearings above 110 mm bore**

Please consult the "SKF Interactive Engineering Catalogue" online at [www.skf.com](http://www.skf.com).

## Double row angular contact ball bearings d 10 – 50 mm

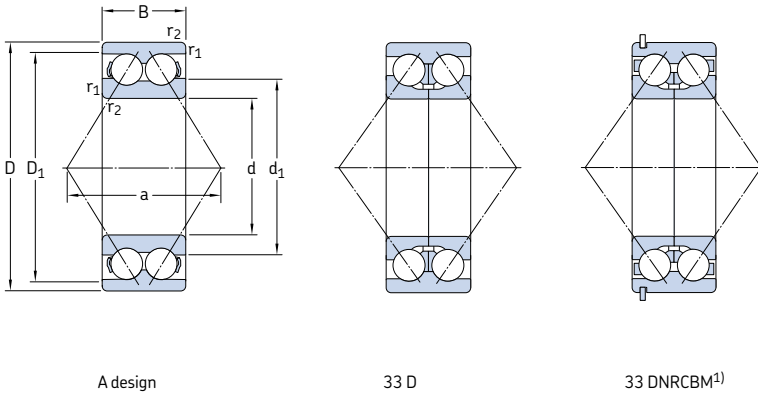

Principal dimensions			Basic load ratings		Fatigue limit P <sub>U</sub>	Speed ratings		Mass	Designations <sup>2)</sup>	
d	D	B	C	C <sub>0</sub>		Refer- ence speed	Limiting speed		Bearing with metal cage	polyamide cage
mm			kN	kN		r/min		kg	–	
10	30	14	7,61	4,3	0,183	22 000	24 000	0,051	–	3200 ATN9
12	32	15,9	10,1	5,6	0,24	20 000	22 000	0,058	–	3201 ATN9
15	35	15,9	11,2	6,8	0,285	17 000	18 000	0,066	–	3202 ATN9
	42	19	15,1	9,3	0,4	15 000	16 000	0,13	–	3302 ATN9
17	40	17,5	14,3	8,8	0,365	15 000	16 000	0,096	–	3203 ATN9
	47	22,2	21,6	12,7	0,54	14 000	14 000	0,18	–	3303 ATN9
20	47	20,6	20	12	0,51	14 000	14 000	0,16	* 3204 A	* 3204 ATN9
	52	22,2	23,6	14,6	0,62	13 000	13 000	0,22	* 3304 A	* 3304 ATN9
25	52	20,6	21,6	14,3	0,6	12 000	12 000	0,18	* 3205 A	* 3205 ATN9
	62	25,4	32	20,4	0,865	11 000	11 000	0,35	* 3305 A	* 3305 ATN9
30	62	23,8	30	20,4	0,865	10 000	10 000	0,29	* 3206 A	* 3206 ATN9
	72	30,2	41,5	27,5	1,16	9 000	9 000	0,53	* 3306 A	* 3306 ATN9
35	72	27	40	28	1,18	9 000	9 000	0,44	* 3207 A	* 3207 ATN9
	80	34,9	52	35,5	1,5	8 500	8 500	0,71	* 3307 A	* 3307 ATN9
	80	34,9	52,7	41,5	1,76	7 500	8 000	0,79	3307 DJ1	–
40	80	30,2	47,5	34	1,43	8 000	8 000	0,58	* 3208 A	* 3208 ATN9
	90	36,5	64	44	1,86	7 500	7 500	1,05	* 3308 A	* 3308 ATN9
	90	36,5	49,4	41,5	1,76	6 700	7 000	1,20	3308 DNRCBM	–
	90	36,5	68,9	64	2,45	6 700	7 000	1,05	3308 DMA	3308 DTN9
45	85	30,2	51	39	1,63	7 500	7 500	0,63	* 3209 A	* 3209 ATN9
	100	39,7	75	53	2,24	6 700	6 700	1,40	* 3309 A	* 3309 ATN9
	100	39,7	61,8	52	2,2	6 000	6 300	1,50	3309 DNRCBM	–
	100	39,7	79,3	69,5	3	6 000	6 300	1,60	3309 DMA	–
50	90	30,2	51	39	1,66	7 000	7 000	0,66	* 3210 A	* 3210 ATN9
	110	44,4	90	64	2,75	6 000	6 000	1,95	* 3310 A	* 3310 ATN9
	110	44,4	81,9	69,5	3	5 300	5 600	1,95	3310 DNRCBM	–
	110	44,4	93,6	85	3,6	5 300	5 600	2,15	3310 DMA	–

\* SKF Explorer bearing

<sup>1)</sup> For dimensions of snap ring groove and snap ring → table 1 on page 437

<sup>2)</sup> For available final variants → matrix 1 on page 441

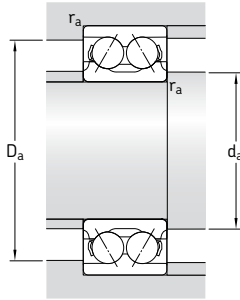

### Dimensions

### Abutment and fillet dimensions

d	$d_1$ ~	$D_1$ ~	$r_{1,2}$ min	a	$d_a$ min	$D_a$ max	$r_a$ max
mm					mm		
10	17,7	23,6	0,6	16	14,4	25,6	0,6
12	19,1	26,5	0,6	19	16,4	27,6	0,6
15	22,1 25,4	29,5 34,3	0,6 1	21 24	19,4 20,6	30,6 36,4	0,6 1
17	25,1 27,3	33,6 38,8	0,6 1	23 28	21,4 22,6	35,6 41,4	0,6 1
20	27,7 29,9	40,9 44,0	1 1,1	28 30	25,6 27	41,4 45	1 1
25	32,7 35,7	45,9 53,4	1 1,1	30 36	30,6 32	46,4 55	1 1
30	38,7 39,8	55,2 64,1	1 1,1	36 42	35,6 37	56,4 65	1 1
35	45,4 44,6 52,8	63,9 70,5 69,0	1,1 1,5 1,5	42 47 76	42 44 44	65 71 71	1 1,5 1,5
40	47,8 50,8 60,1 59,4	72,1 80,5 79,5 80,3	1,1 1,5 1,5 1,5	46 53 71 84	47 49 49 49	73 81 81 81	1 1,5 1,5 1,5
45	52,8 55,6 68 70	77,1 90 87,1 86,4	1,1 1,5 1,5 1,5	49 58 79 93	52 54 54 54	78 91 91 91	1 1,5 1,5 1,5
50	57,8 62 74,6 76,5	82,1 99,5 87 94,2	1,1 2 2 2	52 65 88 102	57 61 61 61	83 99,5 99 99	1 2 2 2

## Double row angular contact ball bearings d 55 – 110 mm

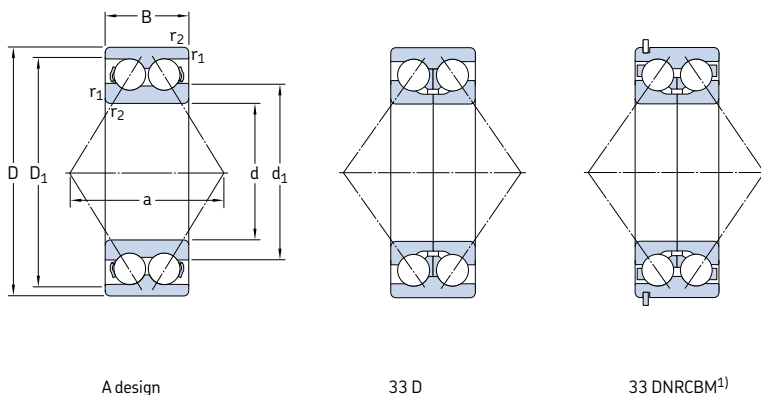

Principal dimensions			Basic load ratings		Fatigue load limit $P_u$	Speed ratings		Mass	Designations <sup>2)</sup> Bearing with metal cage	polyamide cage
d	D	B	C	$C_0$		Reference speed	Limiting speed			
mm			kN		kN	r/min		kg	–	
<b>55</b>	100	33,3	60	47,5	2	6 300	6 300	1,05	* 3211 A	* 3211 ATN9
	120	49,2	112	81,5	3,45	5 300	5 300	2,55	* 3311 A	* 3311 ATN9
	120	49,2	95,6	83	3,55	4 800	5 000	2,55	3311 DNRCBM	–
	120	49,2	111	100	4,3	4 800	5 000	2,80	3311 DMA	–
<b>60</b>	110	36,5	73,5	58,5	2,5	5 600	5 600	1,40	* 3212 A	* 3212 ATN9
	130	54	127	95	4,05	5 000	5 000	3,25	* 3312 A	–
<b>65</b>	120	38,1	80,6	73,5	3,1	4 500	4 800	1,75	3213 A	–
	140	58,7	146	110	4,55	4 500	4 500	4,10	* 3313 A	–
	140	58,7	138	122	5,1	4 300	4 500	4,00	3313 DNRCBM	–
<b>70</b>	125	39,7	88,4	80	3,4	4 300	4 500	1,90	3214 A	–
	150	63,5	163	125	5	4 300	4 300	5,05	* 3314 A	–
<b>75</b>	130	41,3	95,6	88	3,75	4 300	4 500	2,10	3215 A	–
	160	68,3	176	140	5,5	4 000	4 000	5,55	* 3315 A	–
<b>80</b>	140	44,4	106	95	3,9	4 000	4 300	2,65	3216 A	–
	170	68,3	182	156	6	3 400	3 600	6,80	3316 A	–
	170	68,3	190	196	7,35	3 400	3 600	7,55	3316 DMA	–
<b>85</b>	150	49,2	124	110	4,4	3 600	3 800	3,40	3217 A	–
	180	73	195	176	6,55	3 200	3 400	8,30	3317 A	–
<b>90</b>	160	52,4	130	120	4,55	3 400	3 600	4,15	3218 A	–
	190	73	195	180	6,4	3 000	3 200	9,25	3318 A	–
	190	73	225	250	8,8	3 000	3 200	10,0	3318 DMA	–
<b>95</b>	170	55,6	159	146	5,4	3 200	3 400	5,00	3219 A	–
	200	77,8	225	216	7,5	2 800	3 000	11,0	3319 A	–
	200	77,8	242	275	9,5	2 800	3 000	12,0	3319 DMA	–
<b>100</b>	180	60,3	178	166	6	3 000	3 200	6,10	3220 A	–
	215	82,6	255	255	8,65	2 600	2 800	13,5	3320 A	–
<b>110</b>	200	69,8	212	212	7,2	2 800	2 800	8,80	3222 A	–
	240	92,1	291	305	9,8	2 400	2 600	19,0	3322 A	–

\* SKF Explorer bearing

<sup>1)</sup> For dimensions of snap ring groove and snap ring → table 1 on page 437

<sup>2)</sup> For available final variants → matrix 1 on page 441

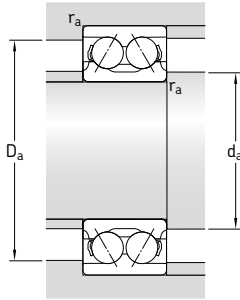
**Dimensions**
**Abutment and fillet dimensions**

d	d <sub>1</sub> ~	D <sub>1</sub> ~	r <sub>1,2</sub> min	a	d <sub>a</sub> min	D <sub>a</sub> max	r <sub>a</sub> max
mm					mm		
<b>55</b>	63,2	92,3	1,5	57	63	92,3	1,5
	68,4	109	2	72	66	109	2
	81,6	106,5	2	97	66	109	2
	81,3	104,4	2	114	66	109	2
<b>60</b>	68,8	101	1,5	63	69	101	1,5
	74,3	118	2,1	78	72	118	2
<b>65</b>	85	103	1,5	71	74	111	1,5
	78,5	130	2,1	84	77	130	2
	95,1	126	2,1	114	77	128	2
<b>70</b>	88,5	107	1,5	74	79	116	1,5
	84,2	139	2,1	89	82	139	2
<b>75</b>	91,9	112	1,5	77	84	121	1,5
	88,8	147	2,1	97	87	148	2
<b>80</b>	97,7	120	2	82	91	129	2
	108	143	2,1	101	92	158	2
	114	145	2,1	158	92	158	2
<b>85</b>	104	128	2	88	96	139	2
	116	153	3	107	99	166	2,5
<b>90</b>	111	139	2	94	101	149	2
	123	160	3	112	104	176	2,5
	130	167	3	178	104	176	2,5
<b>95</b>	119	147	2,1	101	107	158	2
	127	168	3	118	109	186	2,5
	138	177	3	189	109	186	2,5
<b>100</b>	125	155	2,1	107	112	168	2
	136	180	3	127	114	201	2,5
<b>110</b>	139	173	2,1	119	122	188	2
	153	200	3	142	124	226	2,5

**Sealed double row angular contact ball bearings**  
**d 10 – 60 mm**

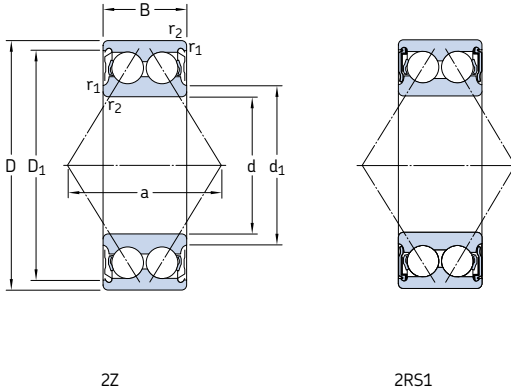

Principal dimensions			Basic load ratings		Fatigue load limit $P_u$	Limiting speeds		Mass	Designations <sup>1)</sup>	
d	D	B	C	$C_0$		Bearing with shields	seals		Bearing with shields	seals
mm			kN		kN	r/min		kg	–	
10	30	14	7,61	4,3	0,183	24 000	17 000	0,051	<b>3200 A-2Z</b>	<b>3200 A-2RS1</b>
12	32	15,9	10,1	5,6	0,24	22 000	15 000	0,058	<b>3201 A-2Z</b>	<b>3201 A-2RS1</b>
15	35	15,9	11,2	6,8	0,285	18 000	14 000	0,066	<b>3202 A-2Z</b>	<b>3202 A-2RS1</b>
	42	19	15,1	9,3	0,4	16 000	12 000	0,13	<b>3302 A-2Z</b>	<b>3302 A-2RS1</b>
17	40	17,5	14,3	8,8	0,365	16 000	12 000	0,10	<b>3203 A-2Z</b>	<b>3203 A-2RS1</b>
	47	22,2	21,6	12,7	0,54	14 000	11 000	0,18	<b>3303 A-2Z</b>	<b>3303 A-2RS1</b>
20	47	20,6	20	12	0,51	14 000	10 000	0,16	<b>* 3204 A-2Z</b>	<b>* 3204 A-2RS1</b>
	52	22,2	23,6	14,6	0,62	13 000	9 000	0,22	<b>* 3304 A-2Z</b>	<b>* 3304 A-2RS1</b>
25	52	20,6	21,6	14,3	0,6	12 000	8 500	0,18	<b>* 3205 A-2Z</b>	<b>* 3205 A-2RS1</b>
	62	25,4	32	20,4	0,865	11 000	7 500	0,35	<b>* 3305 A-2Z</b>	<b>* 3305 A-2RS1</b>
30	62	23,8	30	20,4	0,865	10 000	7 500	0,29	<b>* 3206 A-2Z</b>	<b>* 3206 A-2RS1</b>
	72	30,2	41,5	27,5	1,16	9 000	6 300	0,52	<b>* 3306 A-2Z</b>	<b>* 3306 A-2RS1</b>
35	72	27	40	28	1,18	9 000	6 300	0,44	<b>* 3207 A-2Z</b>	<b>* 3207 A-2RS1</b>
	80	34,9	52	35,5	1,5	8 500	6 000	0,73	<b>* 3307 A-2Z</b>	<b>* 3307 A-2RS1</b>
40	80	30,2	47,5	34	1,43	8 000	5 600	0,57	<b>* 3208 A-2Z</b>	<b>* 3208 A-2RS1</b>
	90	36,5	64	44	1,86	7 500	5 000	0,93	<b>* 3308 A-2Z</b>	<b>* 3308 A-2RS1</b>
45	85	30,2	51	39	1,63	7 500	5 300	0,63	<b>* 3209 A-2Z</b>	<b>* 3209 A-2RS1</b>
	100	39,7	75	53	2,24	6 700	4 800	1,25	<b>* 3309 A-2Z</b>	<b>* 3309 A-2RS1</b>
50	90	30,2	51	39	1,66	7 000	4 800	0,65	<b>* 3210 A-2Z</b>	<b>* 3210 A-2RS1</b>
	110	44,4	90	64	2,75	6 000	4 300	1,70	<b>* 3310 A-2Z</b>	<b>* 3310 A-2RS1</b>
55	100	33,3	60	47,5	2	6 300	4 500	0,91	<b>* 3211 A-2Z</b>	<b>* 3211 A-2RS1</b>
	120	49,2	112	81,5	3,45	5 300	3 800	2,65	<b>* 3311 A-2Z</b>	<b>* 3311 A-2RS1</b>
60	110	36,5	73,5	58,5	2,5	5 600	4 000	1,20	<b>* 3212 A-2Z</b>	<b>* 3212 A-2RS1</b>
	130	54	127	95	4,05	5 000	–	2,80	<b>* 3312 A-2Z</b>	–

\* SKF Explorer bearing

<sup>1)</sup> For available final variants → **matrix 1** on page 441

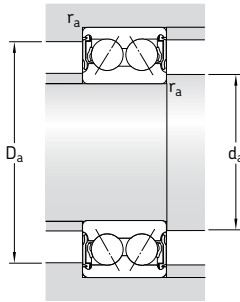
**Dimensions**
**Abutment and fillet dimensions**

d	d <sub>1</sub> ~	D <sub>1</sub> ~	r <sub>1,2</sub> min	a	d <sub>a</sub> min	d <sub>a</sub> max	D <sub>a</sub> max	r <sub>a</sub> max
mm					mm			
<b>10</b>	15,8	25	0,6	16	14,4	15,5	25,6	0,6
<b>12</b>	17,2	27,7	0,6	19	16,4	17	27,7	0,6
<b>15</b>	20,2 23,7	30,7 35,7	0,6 1	21 24	19,4 20,6	20 23,5	30,7 36,4	0,6 1
<b>17</b>	23,3 25,7	35 40,2	0,6 1	23 28	21,4 22,6	23 25,5	35,6 41,4	0,6 1
<b>20</b>	27,7 29,9	40,9 44	1 1,1	28 30	25,6 27	27,5 29,5	41,4 45	1 1
<b>25</b>	32,7 35,7	45,9 53,4	1 1,1	30 36	30,6 32	32,5 35,5	46,4 55	1 1
<b>30</b>	38,7 39,8	55,2 64,1	1 1,1	36 42	35,6 37	38,5 39,5	56,4 65	1 1
<b>35</b>	45,4 44,6	63,9 70,5	1,1 1,5	42 47	42 44	45 44,5	65 71	1 1,5
<b>40</b>	47,8 50,8	72,1 80,5	1,1 1,5	46 53	47 49	47 50,5	73 81	1 1,5
<b>45</b>	52,8 55,6	77,1 90	1,1 1,5	49 58	52 54	52,5 55,5	78 91	1 1,5
<b>50</b>	57,8 62	82,1 99,5	1,1 2	52 65	57 61	57,5 61,5	83 99,5	1 2
<b>55</b>	63,2 68,4	92,3 109	1,5 2	57 72	63 66	63 68	92,3 109	1,5 2
<b>60</b>	68,8 73,4	101 118	1,5 2,1	63 78	68,5 72	68,5 73	101 118	1,5 2

**Sealed double row angular contact ball bearings**  
**d 65 – 75 mm**

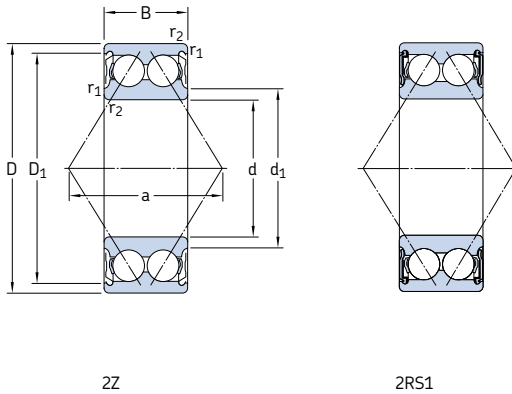

Principal dimensions			Basic load ratings		Fatigue load limit $P_u$	Limiting speeds		Mass	Designations <sup>1)</sup>	
d	D	B	dynamic	static		Bearing with shields	seals		Bearing with shields	seals
mm			kN		kN	r/min		kg	–	
<b>65</b>	120	38,1	80,6	73,5	3,1	4 800	3 600	1,75	<b>3213 A-2Z</b>	<b>3213 A-2RS1</b>
	140	58,7	146	110	4,55	4 500	–	4,10	<b>* 3313 A-2Z</b>	–
<b>70</b>	125	39,7	88,4	80	3,4	4 500	–	1,90	<b>3214 A-2Z</b>	–
	150	63,5	163	125	5	4 300	–	5,05	<b>* 3314 A-2Z</b>	–
<b>75</b>	130	41,3	95,6	88	3,75	4 500	–	2,10	<b>3215 A-2Z</b>	–
	160	68,3	176	140	5,5	4 000	–	5,60	<b>* 3315 A-2Z</b>	–

\* SKF Explorer bearing  
<sup>1)</sup> For available final variants → **matrix 1 on page 441**

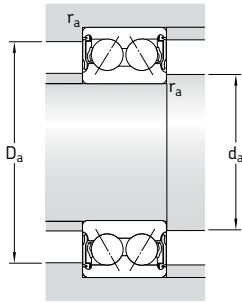
**Dimensions**
**Abutment and fillet dimensions**

d	d <sub>1</sub> ~	D <sub>1</sub> ~	r <sub>1,2</sub> min	a	d <sub>a</sub> min	d <sub>a</sub> max	D <sub>a</sub> max	r <sub>a</sub> max
mm					mm			
<b>65</b>	76,3	113	1,5	71	74	76	113	1,5
	78,5	130	2,1	84	77	78,5	130	2
<b>70</b>	82	118	1,5	74	79	82	118	1,5
	84,2	139	2,1	89	82	84	139	2
<b>75</b>	84,6	123	1,5	77	84	84	123	1,5
	88,8	147	2,1	97	87	88,5	148	2



# Four-point contact ball bearings

<b>Designs .....</b>	<b>452</b>
Basic design bearings .....	452
Bearings with locating slots .....	452
<b>SKF Explorer class bearings .....</b>	<b>453</b>
<b>Bearing data – general .....</b>	<b>453</b>
Dimensions .....	453
Tolerances .....	453
Internal clearance .....	453
Misalignment .....	454
Influence of operating temperature on bearing material .....	454
Cages .....	454
Minimum load .....	454
Equivalent dynamic bearing load .....	455
Equivalent static bearing load .....	455
Supplementary designations .....	455
<b>Design of bearing arrangements .....</b>	<b>455</b>
<b>Product table .....</b>	<b>456</b>

### Designs

Four-point contact ball bearings are radial single row angular contact ball bearings with raceways that are designed to support axial loads acting in both directions. Radial loads can be supported up to a certain fraction of the axial load. These bearings take up considerably less axial space than double row bearings.

The standard range of SKF four-point contact ball bearings comprises bearings in the QJ 2 and QJ 3 series (→ **fig. 1**). They are available as

- basic design bearings or
- bearings with locating slots.

In addition, SKF four-point contact ball bearings are available in other dimension series, designs, and sizes. For information on these bearings, consult the “SKF Interactive Engineering Catalogue” online at [www.skf.com](http://www.skf.com).

### Basic design bearings

Four-point contact ball bearings shown in this catalogue have a 35° contact angle and are designed to accommodate predominantly axial loads. The inner ring is split. This enables a large number of balls to be incorporated in the bearing thus giving the bearing high load carrying capacity. The bearings are separable, i.e. the outer ring with ball and cage assembly can be mounted separately from the two inner ring halves.

Both inner ring halves of SKF Explorer four-point contact ball bearings have a recessed shoulder. This improves the oil flow when the bearing is used together with an SKF cylindrical roller bearing (→ **fig. 2**). In addition, these recesses can be used to facilitate dismounting.

### Bearings with locating slots

In many applications a radial bearing is used in combination with a four-point contact ball bearing which acts as a pure thrust bearing and is mounted with radial clearance in the housing (→ **fig. 2**). To restrain the outer ring from turning in the circumferential direction, bearings with two locating slots (designation suffix N2) in the outer ring positioned at 180° to each other are available (→ **fig. 3**).

Fig. 1

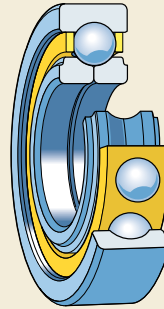

Fig. 2

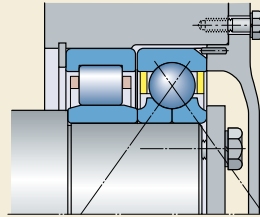
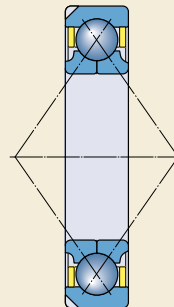

Fig. 3



# SKF Explorer class bearings

High performance SKF Explorer four-point contact ball bearings are shown with an asterisk in the product table. SKF Explorer bearings retain the designation of the earlier standard bearings, e.g. QJ 309 N2MA. However, each bearing and its box are marked with the name “EXPLORER”.

SKF Explorer four-point contact ball bearings meet the specifications for tolerance class P6, except that the width tolerance is reduced to 0/-40 µm.

The values for tolerances correspond to ISO 492:2002 and can be found in **tables 3 and 4** on **pages 125 and 126**.

## Bearing data – general

### Dimensions

The boundary dimensions of SKF four-point contact ball bearings are in accordance with ISO 15:1998.

### Tolerances

SKF four-point contact ball bearings are produced as standard to Normal tolerances. Some sizes are also available with enhanced precision to tolerance class P6 specifications.

### Internal clearance

SKF four-point contact ball bearings are supplied with Normal axial internal clearance as standard, but some sizes are available with greater or smaller clearance, or with reduced clearance limits.

The actual clearance limits are provided in **table 1** and are valid for bearings before mounting under zero measuring load.

Table 1

Axial internal clearance of four-point contact ball bearings

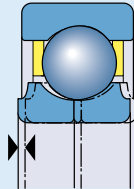

Bore diameter d		Axial internal clearance C2				Normal		C3		C4	
		min	max	min	max	min	max	min	max		
over	incl.	µm									
mm		µm									
10	17	15	55	45	85	75	125	115	165	206	
17	40	26	66	56	106	96	146	136	186	246	
40	60	36	86	76	126	116	166	156	206	266	
60	80	46	96	86	136	126	176	166	226	286	
80	100	56	106	96	156	136	196	186	246	306	
100	140	66	126	116	176	156	216	206	266	326	
140	180	76	156	136	196	176	246	226	286	346	
180	220	96	176	156	226	206	276	256	316	376	

## Four-point contact ball bearings

### Misalignment

The ability of four-point contact ball bearings to tolerate misalignment of the inner ring with respect to the outer ring, and consequently the ability to compensate for misalignment in the application or to tolerate shaft deflections is limited. It depends on the internal clearance in operation, bearing size and the magnitude of the forces and moments acting on the bearing. The interrelationship of these factors is complex and no general rules can be provided.

Any misalignment will lead to increased running noise, cage stresses and reduced bearing service life.

### Influence of operating temperature on bearing material

SKF four-point contact ball bearings undergo a special heat treatment. When fitted with a brass or PEEK cage, they can operate at temperatures of up to +150 °C.

### Cages

SKF four-point contact ball bearings are fitted with one of the following cages

- a machined window-type brass cage, outer ring centred, designation suffix MA (→ fig. 4)
- an injection moulded window-type cage of glass fibre reinforced polyetheretherketone (PEEK) with lubrication grooves in the guiding surfaces, outer ring centred, designation suffix PHAS.

If bearings with a PEEK cage are required, other than listed, please contact the SKF application engineering service.

### Minimum load

In order to provide satisfactory operation, four-point contact ball bearings, like all ball and roller bearings, must always be subjected to a given minimum load, particularly if they are to operate at high speeds or are subjected to high accelerations or rapid changes in the direction of load. Under such conditions, inertia forces of the balls and cage, and the friction in the lubricant, can have a detrimental influence on the rolling conditions in the bearing and may cause sliding

damaging movements to occur between the balls and raceways.

The requisite minimum load to be applied to four-point contact ball bearings can be estimated using

$$F_{am} = k_a \frac{C_0}{1\,000} \left( \frac{n d_m}{100\,000} \right)^2$$

where

$F_{am}$  = minimum axial load, kN

$k_a$  = minimum axial load factor

1 for bearings in the QJ 2 series

1,1 for bearings in the QJ 3 series

$C_0$  = basic static load rating, kN  
(→ product table)

$n$  = rotational speed, r/min

$d_m$  = bearing mean diameter  
= 0,5 (d + D), mm

When starting up at low temperatures or when the lubricant is highly viscous, even greater minimum loads may be required. The weight of the components supported by the bearing, together with external forces, generally exceeds the requisite minimum load. If this is not the case, the four-point contact ball bearing must be subjected to an additional axial load, for example, by means of springs.

Fig. 4

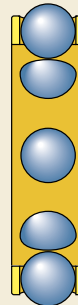

## Equivalent dynamic bearing load

If four-point contact ball bearings are arranged as locating bearings and have to accommodate both radial and axial loads, the equivalent dynamic bearing load is obtained from

$$P = F_r + 0,66 F_a \quad \text{when } F_a/F_r \leq 0,95$$
$$P = 0,6 F_r + 1,07 F_a \quad \text{when } F_a/F_r > 0,95$$

It should be noted that four-point contact ball bearings will only function properly when the ball contacts at only one point on the outer ring raceway and at one point on the inner ring raceway. This is the case if the axial load  $F_a \geq 1,27 F_r$ .

If the four-point contact ball bearing is arranged with radial freedom in the housing to act as a thrust bearing in combination with a radial bearing (the usual arrangement for these bearings, → **fig. 2** on **page 452**), then the equivalent dynamic bearing load becomes

$$P = 1,07 F_a$$

## Equivalent static bearing load

$$P_0 = F_r + 0,58 F_a$$

## Supplementary designations

The designation suffixes used to identify certain features of SKF four-point contact ball bearings are explained in the following.

<b>B20</b>	Reduced width tolerance
<b>C2</b>	Axial internal clearance smaller than Normal
<b>C2H</b>	Axial internal clearance in the upper half of the C2 range
<b>C2L</b>	Axial internal clearance in the lower half of the C2 range
<b>C3</b>	Axial internal clearance greater than Normal
<b>C4</b>	Axial internal clearance greater than C3
<b>CNL</b>	Axial internal clearance in the lower half of the Normal range
<b>FA</b>	Machined window-type steel cage, outer ring centred
<b>MA</b>	Machined window-type brass cage, outer ring centred

<b>N2</b>	Two locating slots (notches), 180° apart, in one of the outer ring side faces
<b>PHAS</b>	Injection moulded window-type cage of glass fibre reinforced polyetheretherketone (PEEK), with lubrication grooves in the guiding surfaces, outer ring centred
<b>P6</b>	Dimensional and running accuracy to ISO tolerance class 6
<b>P63</b>	P6 + C3
<b>P64</b>	P6 + C4
<b>S1</b>	Bearing rings dimensionally stabilized for use at operating temperatures up to +200 °C
<b>344524</b>	C2H + CNL

## Design of bearing arrangements

The outer ring of bearings, which are arranged as thrust bearings with radial clearance in the housing, should not be clamped (→ **fig. 2**, **page 452**). Otherwise the outer ring cannot compensate for thermal movements, which will cause additional force in the bearing. If clamping the outer ring cannot be avoided, the outer ring must be at least carefully centred during mounting.

# Four-point contact ball bearings

## d 15 – 65 mm

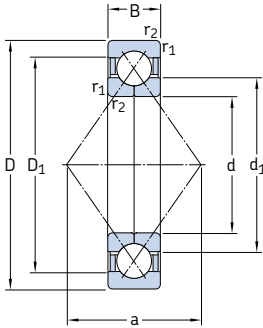

Basic design

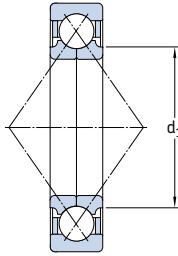

SKF Explorer bearing

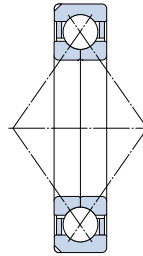

Bearing with locating slots

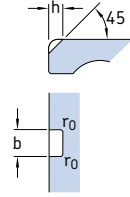

Principal dimensions		Basic load ratings dynamic static		Fatigue load limit $P_u$	Speed ratings Refer- ence speed		Mass	Designations Bearing with locating slots	without locating slots	
d	D	B	C		$C_0$	Reference speed				Limiting speed
mm			kN	kN	r/min		kg	–		
15	35	11	12,7	8,3	0,36	22 000	36 000	0,062	<b>QJ 202 N2MA</b>	–
17	40 47	12 14	15,9 23,4	10,6 15	0,45 0,64	19 000 17 000	30 000 28 000	0,082 0,14	<b>* QJ 203 N2MA</b> <b>QJ 303 N2MA</b>	–
20	52 52	15 15	32 32	21,6 21,6	0,85 0,85	18 000 20 000	24 000 24 000	0,18 0,18	<b>* QJ 304 N2MA</b> <b>* QJ 304 N2PHAS</b>	<b>* QJ 304 MA</b> –
25	52 62	15 17	27 39	21,2 28	0,83 1,18	16 000 12 000	22 000 20 000	0,16 0,29	<b>* QJ 205 N2MA</b> <b>* QJ 305 N2MA</b>	<b>* QJ 205 MA</b> <b>* QJ 305 MA</b>
30	62 72 72	16 19 19	37,5 53 53	30,5 41,5 41,5	1,2 1,63 1,63	14 000 12 000 14 000	19 000 17 000 17 000	0,24 0,42 0,42	<b>* QJ 206 N2MA</b> <b>* QJ 306 N2MA</b> <b>* QJ 306 N2PHAS</b>	<b>* QJ 206 MA</b> <b>* QJ 306 MA</b> –
35	72 80 80	17 21 21	49 64 64	41,5 51 51	1,63 1,96 1,96	12 000 11 000 13 000	17 000 15 000 15 000	0,36 0,57 0,57	<b>* QJ 207 N2MA</b> <b>* QJ 307 N2MA</b> <b>* QJ 307 N2PHAS</b>	– <b>* QJ 307 MA</b> –
40	80 90	18 23	56 78	49 64	1,9 2,45	11 000 10 000	15 000 14 000	0,45 0,78	<b>* QJ 208 N2MA</b> <b>* QJ 308 N2MA</b>	<b>* QJ 208 MA</b> <b>* QJ 308 MA</b>
45	85 100 100	19 25 25	63 100 100	56 83 83	2,16 3,25 3,25	10 000 9 000 10 000	14 000 12 000 12 000	0,52 1,05 1,05	– <b>* QJ 309 N2MA</b> <b>* QJ 309 N2PHAS</b>	<b>* QJ 209 MA</b> <b>* QJ 309 MA</b> –
50	90 110 110	20 27 27	65,5 118 118	61 100 100	2,4 3,9 3,9	9 000 8 000 9 000	13 000 11 000 11 000	0,59 1,35 1,35	– – –	<b>* QJ 210 MA</b> <b>* QJ 310 MA</b> <b>* QJ 310 PHAS</b>
55	100 120	21 29	85 137	83 118	3,2 4,55	8 000 7 000	11 000 10 000	0,77 1,75	<b>* QJ 211 N2MA</b> <b>* QJ 311 N2MA</b>	<b>* QJ 211 MA</b> <b>* QJ 311 MA</b>
60	110 110 130	22 22 31	96,5 96,5 156	93 93 137	3,65 3,65 5,3	7 500 8 500 6 700	10 000 10 000 9 000	0,99 0,99 2,15	<b>* QJ 212 N2MA</b> <b>* QJ 212 N2PHAS</b> <b>* QJ 312 N2MA</b>	<b>* QJ 212 MA</b> – <b>* QJ 312 MA</b>
65	120 140	23 33	110 176	112 156	4,4 6,1	6 700 6 300	9 500 8 500	1,20 2,70	<b>* QJ 213 N2MA</b> –	<b>* QJ 213 MA</b> <b>* QJ 313 MA</b>

\* SKF Explorer bearing

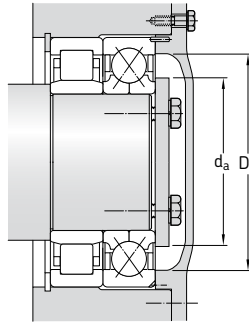
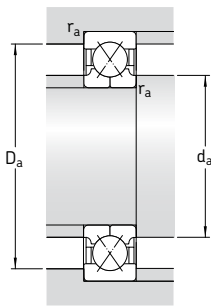

Dimensions					Slot dimensions			Abutment and fillet dimensions		
d	d <sub>1</sub>	D <sub>1</sub>	r <sub>1,2</sub> min	a	b	h	r <sub>0</sub>	d <sub>a</sub> min	D <sub>a</sub> max	r <sub>a</sub> max
mm					mm			mm		
15	22	28,1	0,6	18	3	2,2	0,5	19,2	30,8	0,6
17	23,5 27,7	32,5 36,3	0,6 1	20 22	3,5 4,5	2,5 3,5	0,5 0,5	21,2 22,6	35,8 41,4	0,6 1
20	27,5 27,5	40,8 40,8	1,1 1,1	25 25	4,5 4,5	3,5 3,5	0,5 0,5	27 27	45 45	1 1
25	31,5 34	43 49	1 1,1	27 30	4,5 4,5	3 3,5	0,5 0,5	30,6 32	46,4 55	1 1
30	37,5 40,5 40,5	50,8 58,2 58,2	1 1,1 1,1	32 36 36	4,5 4,5 4,5	3,5 3,5 3,5	0,5 0,5 0,5	35,6 37 37	56,4 65 65	1 1 1
35	44 46,2 46,2	59 64,3 64,3	1,1 1,5 1,5	37 40 40	4,5 5,5 5,5	3,5 4 4	0,5 0,5 0,5	42 44 44	65 71 71	1 1,5 1,5
40	49,5 52	66 72,5	1,1 1,5	42 46	5,5 5,5	4 4	0,5 0,5	47 49	73 81	1 1,5
45	54,5 58 58	71,5 81,2 81,2	1,1 1,5 1,5	46 51 51	– 6,5 6,5	– 5 5	– 0,5 0,5	52 54 54	78 91 91	1 1,5 1,5
50	59,5 65 65	76,5 89,5 89,5	1,1 2 2	49 56 56	– – –	– – –	– – –	57 61 61	83 99 99	1 2 2
55	66 70,5	84,7 97,8	1,5 2	54 61	6,5 6,5	5 8,1	0,5 0,5	64 66	91 109	1,5 2
60	72 72 77	93 93 106	1,5 1,5 2,1	60 60 67	6,5 6,5 6,5	5 5 8,1	0,5 0,5 0,5	69 69 72	101 101 118	1,5 1,5 2
65	78,5 82,5	101 115	1,5 2,1	65 72	6,5 –	6,5 –	0,5 –	74 77	111 128	1,5 2

# Four-point contact ball bearings

## d 70 – 150 mm

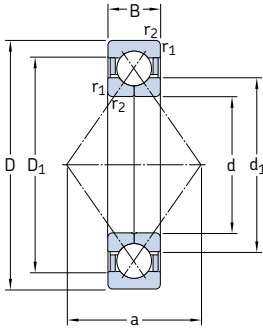

Basic design

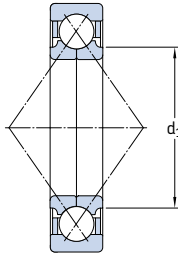

SKF Explorer bearing

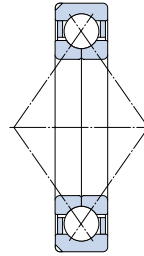

Bearing with locating slots

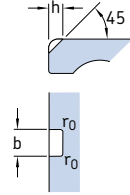

Principal dimensions		Basic load ratings dynamic static		Fatigue load limit $P_u$	Speed ratings Reference speed Limiting speed		Mass	Designations Bearing with locating slots	without locating slots	
d	D	B	C	$C_0$						
mm			kN		kN	r/min	kg	–		
70	125	24	120	122	4,8	6 300	9 000	1,30	* QJ 214 N2MA	* QJ 214 MA
	125	24	120	122	4,8	7 500	9 000	1,30	* QJ 214 N2PHAS	–
	150	35	200	180	6,7	5 600	8 000	3,15	* QJ 314 N2MA	* QJ 314 MA
	150	35	200	180	6,7	6 700	8 000	3,15	* QJ 314 N2PHAS	–
75	130	25	125	132	5,2	6 300	8 500	1,45	* QJ 215 N2MA	* QJ 215 MA
	130	25	125	132	5,2	7 000	8 500	1,45	* QJ 215 N2PHAS	–
	160	37	216	200	7,35	5 300	7 500	3,90	* QJ 315 N2MA	–
80	140	26	146	156	5,85	5 600	8 000	1,85	* QJ 216 N2MA	* QJ 216 MA
	170	39	232	228	8	5 000	7 000	4,60	* QJ 316 N2MA	–
85	150	28	156	173	6,2	5 300	7 500	2,25	* QJ 217 N2MA	* QJ 217 MA
	180	41	250	255	8,65	4 800	6 700	5,45	* QJ 317 N2MA	–
90	160	30	186	200	6,95	5 000	7 000	2,75	* QJ 218 N2MA	–
	190	43	285	305	10,2	4 500	6 300	6,45	* QJ 318 N2MA	–
95	170	32	212	232	7,8	4 800	6 700	3,35	* QJ 219 N2MA	–
	200	45	305	340	11	4 300	6 000	7,45	* QJ 319 N2MA	–
100	180	34	236	265	8,65	4 500	6 300	4,05	* QJ 220 N2MA	–
	215	47	345	400	12,5	4 000	5 600	9,30	* QJ 320 N2MA	–
110	200	38	280	325	10,4	4 000	5 600	5,60	* QJ 222 N2MA	–
	240	50	390	480	14,3	3 600	4 800	12,5	* QJ 322 N2MA	–
120	215	40	300	365	11,2	3 600	5 000	6,95	* QJ 224 N2MA	–
	260	55	415	530	15	3 200	4 500	16,0	* QJ 324 N2MA	–
130	230	40	310	400	11,6	3 400	4 800	7,75	* QJ 226 N2MA	–
	280	58	455	610	16,6	3 000	4 000	19,5	* QJ 326 N2MA	–
140	250	42	345	475	13,2	3 200	4 300	9,85	* QJ 228 N2MA	–
	300	62	500	695	18,6	2 800	3 800	24,0	* QJ 328 N2MA	–
150	270	45	400	570	15,3	3 000	4 000	12,5	* QJ 230 N2MA	–
	320	65	530	765	19,6	2 600	3 600	29,0	* QJ 330 N2MA	–

\* SKF Explorer bearing

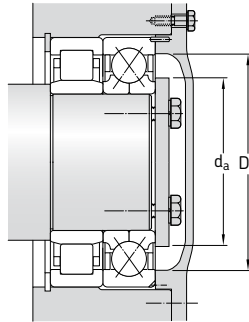
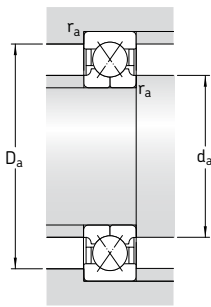

Dimensions					Slot dimensions			Abutment and fillet dimensions		
d	d <sub>1</sub>	D <sub>1</sub>	r <sub>1,2</sub> min	a	b	h	r <sub>0</sub>	d <sub>a</sub> min	D <sub>a</sub> max	r <sub>a</sub> max
mm					mm			mm		
70	83,5	106	1,5	68	6,5	6,5	0,5	79	116	1,5
	83,5	106	1,5	68	6,5	6,5	0,5	79	116	1,5
	89	123	2,1	77	8,5	10,1	2	82	138	2
	89	123	2,1	77	8,5	10,1	2	82	138	2
75	88,5	111	1,5	72	6,5	6,5	0,5	84	121	1,5
	88,5	111	1,5	72	6,5	6,5	0,5	84	121	1,5
	95	131	2,1	82	8,5	10,1	2	87	148	2
80	95,3	120	2	77	6,5	8,1	1	91	129	2
	101	140	2,1	88	8,5	10,1	2	92	158	2
85	100	128	2	83	6,5	8,1	1	96	139	2
	108	148	3	93	10,5	11,7	2	99	166	2,5
90	107	136	2	88	6,5	8,1	1	101	149	2
	113	156	3	98	10,5	11,7	2	104	176	2,5
95	112	145	2,1	93	6,5	8,1	1	107	158	2
	121	165	3	103	10,5	11,7	2	109	186	2,5
100	119	153	2,1	98	8,5	10,1	2	112	168	2
	127	176	3	110	10,5	11,7	2	114	201	2,5
110	132	170	2,1	109	8,5	10,1	2	122	188	2
	143	195	3	123	10,5	11,7	2	124	226	2,5
120	143	183	2,1	117	10,5	11,7	2	132	203	2
	154	211	3	133	10,5	11,7	2	134	246	2,5
130	153	195	3	126	10,5	11,7	2	144	216	2,5
	167	227	4	144	10,5	12,7	2	147	263	3
140	169	211	3	137	10,5	11,7	2	154	236	2,5
	180	244	4	154	10,5	12,7	2	157	283	3
150	182	228	3	147	10,5	11,7	2	164	256	2,5
	193	259	4	165	10,5	12,7	2	167	303	3

**Four-point contact ball bearings**  
**d 160 – 200 mm**

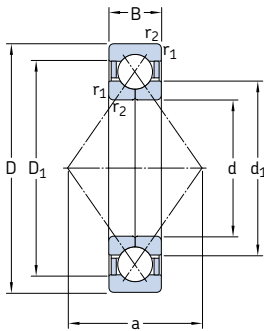

Basic design

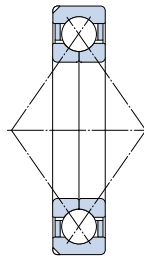

Bearing with locating slots

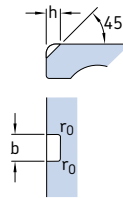

Principal dimensions		Basic load ratings dynamic static		Fatigue load limit $P_u$	Speed ratings Reference speed Limiting speed		Mass	Designation Bearing with locating slots	
d	D	B	C	$C_0$					
mm			kN		kN	r/min	kg	–	
<b>160</b>	290	48	450	670	17,6	2 800	3 800	15,5	* QJ 232 N2MA
	340	68	570	880	21,6	2 400	3 400	34,5	* QJ 332 N2MA
<b>170</b>	310	52	455	720	18,3	2 600	3 400	19,5	* QJ 234 N2MA
	360	72	655	1 040	25	2 200	3 200	41,5	* QJ 334 N2MA
<b>180</b>	320	52	475	765	19	2 400	3 400	20,5	* QJ 236 N2MA
	380	75	680	1 020	26	2 200	3 000	47,5	* QJ 336 N2MA
<b>190</b>	400	78	702	1 160	28,5	1 700	2 800	49,0	QJ 338 N2MA
<b>200</b>	360	58	540	915	23,2	1 800	3 000	28,5	QJ 240 N2MA

\* SKF Explorer bearing

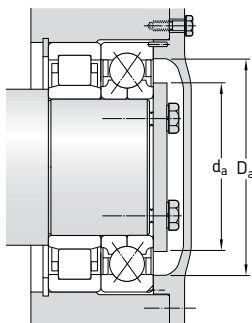
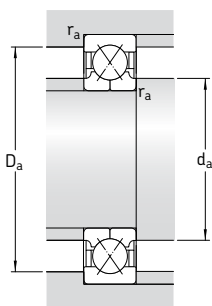

Dimensions					Slot dimensions			Abutment and fillet dimensions		
d	d <sub>1</sub> ~	D <sub>1</sub> ~	r <sub>1,2</sub> min	a	b	h	r <sub>0</sub>	d <sub>a</sub> min	D <sub>a</sub> max	r <sub>a</sub> max
mm					mm			mm		
<b>160</b>	195	244	3	158	10,5	12,7	2	174	276	2,5
	204	276	4	175	10,5	12,7	2	177	323	3
<b>170</b>	207	259	4	168	10,5	12,7	2	187	293	3
	218	293	4	186	10,5	12,7	2	187	343	3
<b>180</b>	217	269	4	175	10,5	12,7	2	197	303	3
	231	309	4	196	10,5	12,7	2	197	363	3
<b>190</b>	263	326	5	207	10,5	12,7	2	212	378	4
<b>200</b>	258	302	4	196	10,5	12,7	2	217	343	3

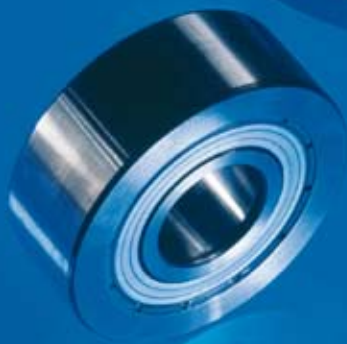

# Double row cam rollers

<b>Designs .....</b>	<b>464</b>
<b>Bearing data – general .....</b>	<b>464</b>
Dimensions.....	464
Tolerances.....	464
Internal clearance.....	464
Cages.....	465
Load carrying ability.....	465
Axial load carrying capacity.....	465
<b>Design of associated components .....</b>	<b>465</b>
Pins .....	465
Guide flanges .....	465
<b>Lubrication .....</b>	<b>465</b>
<b>Product table .....</b>	<b>466</b>

### Designs

SKF double row cam rollers (→ **fig. 1**) have been developed from double row angular contact ball bearings and have a  $30^\circ$  contact angle. They are ready-to-mount pre-greased units and are used for all types of cam drives, conveyor systems etc. They are fitted with pressed steel shields which extend into recesses in the inner ring side faces to keep the lubricant in and contamination out.

Double row SKF cam rollers are available in two designs

- with a crowned runner surface, series 3058(00) C-2Z
- with a cylindrical (flat) runner surface, series 3057(00) C-2Z.

Cam rollers with crowned runner surfaces should be used where there is angular misalignment with respect to the track and where edge stresses need to be minimized. In addition to the double row cam rollers, the SKF standard range of track runner bearings contains other cam rollers, support rollers, and cam followers. These are, for example

- single row cam rollers, series 3612(00) R (→ **page 399**)
- support rollers based on needle roller or cylindrical roller bearings
- cam followers based on needle roller or cylindrical roller bearings.

For additional information on support rollers and cam followers, consult the catalogue "Needle roller bearings" or the "SKF Interactive Engineering Catalogue" online at [www.skf.com](http://www.skf.com).

### Bearing data – general

#### Dimensions

Except for the outside diameter, boundary dimensions of SKF double row cam rollers are in accordance with ISO 15:1998 for bearings in the 32 dimension series.

Fig. 1

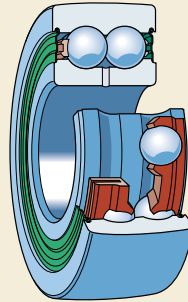
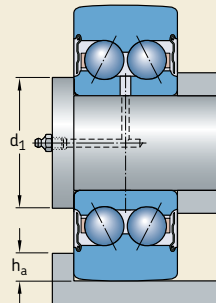

Fig. 2



#### Tolerances

SKF double row cam rollers are produced to Normal tolerances as standard, except for the tolerance of the diameter of the crowned runner surface, which is twice the Normal tolerance.

The values for tolerances correspond to ISO 492:2002 and can be found in **table 3** on **page 125**.

#### Internal clearance

Double row cam rollers are produced with the Normal axial internal clearance of double row angular contact ball bearings (→ **table 2** on **page 438**).

## Cages

Double row cam rollers are fitted with two injection moulded snap-type cages of glass fibre reinforced polyamide 6,6, ball centred, no designation suffix. They can operate at temperatures of up to +120 °C.

## Load carrying ability

In contrast to normal ball bearings, where the outer ring is supported over its entire outside diameter surface in the bore of a housing, the outer ring of a cam roller has only a small contact area with the surface against which it runs, e.g. a rail or cam. The actual contact area depends on the applied radial load and whether the runner surface is crowned or cylindrical. The deformation of the outer ring caused by this limited contact alters the force distribution in the bearing and thus has an influence on load carrying ability. The basic load ratings provided in the product table take this into account.

The ability to carry dynamic loads depends on the requisite life, but with reference to the deformation and the strength of the outer ring, the value of the maximum dynamic radial load  $F_r$  must not be exceeded.

The permissible static load for a cam roller is determined by the smaller of the values of  $F_{0r}$  and  $C_0$ . If requirements regarding smooth running are below normal, the static load may exceed  $C_0$  but should never exceed the maximum permissible static radial load  $F_{0r}$ .

## Axial load carrying capacity

Cam rollers are intended for predominantly radial loads. If an axial load acts on the outer ring, as when the cam roller runs against a guide flange, it will produce a tilting moment and the service life of the cam roller may be reduced as a consequence.

# Design of associated components

## Pins

With few exceptions, cam rollers operate with outer ring rotation. If easy displacement of the inner ring is required, the pin or shaft should be machined to a g6 tolerance. If, however, a tighter fit is required, then the pin or shaft should be machined to a j6 tolerance.

For cam rollers subjected to heavier axial loads, the inner ring should be supported over its entire side face (→ **fig. 2**). The diameter of the supporting surface should be the same as the face diameter  $d_1$  of the inner ring.

## Guide flanges

For rails or cams with guide flanges (→ **fig. 2**), the recommended flange height  $h_a$  should not exceed

$$h_a = 0,5 (D - D_1)$$

This helps to avoid damage to shields fitted in the outer ring. The values for the outer ring diameters  $D$  and  $D_1$  are listed in the product table.

## Lubrication

SKF double row cam rollers are filled with a grease with lithium thickener of consistency 3 to the NLGI Scale. This grease has good rust inhibiting properties and has a temperature range of  $-30$  to  $+120$  °C<sup>1)</sup>. The base oil viscosity is 98 mm<sup>2</sup>/s at 40 °C and 9,4 mm<sup>2</sup>/s at 100 °C.

Under normal operating conditions, these cam rollers are maintenance-free. However, if they are subjected to moisture or solid contaminants, or if they run for long periods at temperatures above 70 °C they should be relubricated. The inner ring has a lubrication hole for this purpose. A grease with lithium thickener should be used for relubrication, preferably the SKF LGMT 3 grease. The grease should be applied slowly to avoid damaging the shields.

<sup>1)</sup> For safe operating temperature, → section "Temperature range – the SKF traffic light concept", starting on **page 232**

**Double row cam rollers**  
**D 32 – 80 mm**

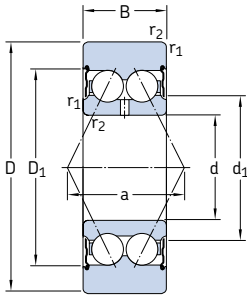

3057(00) C-2Z

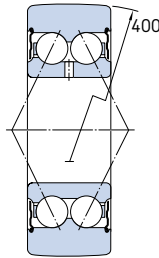

3058(00) C-2Z

Dimensions							Limiting speed	Mass	Designations	
D	B	d	d <sub>1</sub>	D <sub>1</sub>	r <sub>1,2</sub> min	a			Cam roller with crowned runner surface	cylindrical runner surface
mm							r/min	kg	-	
32	14	10	15,8	25	0,6	16	11 000	0,06	<b>305800 C-2Z</b>	-
35	15,9	12	17,2	27,7	0,6	19	9 500	0,076	<b>305801 C-2Z</b>	<b>305701 C-2Z</b>
40	15,9	15	20,2	30,7	0,6	21	9 000	0,10	<b>305802 C-2Z</b>	<b>305702 C-2Z</b>
47	17,5	17	23,3	35	0,6	23	8 000	0,16	<b>305803 C-2Z</b>	<b>305703 C-2Z</b>
52	20,6	20	27,7	40,9	1	28	7 000	0,22	<b>305804 C-2Z</b>	<b>305704 C-2Z</b>
62	20,6	25	32,7	45,9	1	30	6 000	0,32	<b>305805 C-2Z</b>	<b>305705 C-2Z</b>
72	23,8	30	38,7	55,2	1	36	5 000	0,48	<b>305806 C-2Z</b>	<b>305706 C-2Z</b>
80	27	35	45,4	63,9	1,1	42	4 300	0,64	<b>305807 C-2Z</b>	<b>305707 C-2Z</b>

Outside diameter D	Basic load ratings		Fatigue load limit $P_u$	Maximum radial loads	
	dynamic C	static $C_0$		dynamic $F_r$	static $F_{0r}$
mm	kN		kN	kN	
32	7,28	3,65	0,156	4,25	6
35	9,75	4,75	0,20	3,9	5,6
40	10,8	5,7	0,24	6	8,5
47	13,8	7,65	0,325	9,5	13,4
52	17,8	9,8	0,415	8,3	12
62	19,9	12,2	0,52	15,3	22
72	27,0	17,0	0,71	17,3	24,5
80	34,5	21,6	0,915	16,6	24